

高知工科大学

基礎数学ワークブック

(2004年度版)

入門編

No. 4

解答

< 1 ページ. 面積関数 1 >

問 1 の解答

(1) $S(t) = t$

(2) $S(t) = \frac{1}{2}t^2$

(3) $S(t) = \frac{1}{2}\{1 + (1 + 2t)\}t = t + t^2$

(4) $S(t) = \frac{1}{2}\{3 + (3 + \frac{1}{2}t)\}t = 3t + \frac{1}{4}t^2$

問 2 の解答

(1) $\int_0^t 1dx = [x]_0^t = t$

(2) $\int_0^t xdx = \left[\frac{1}{2}x^2\right]_0^t = \frac{1}{2}t^2$

(3) $\int_0^t (1 + 2x)dx = [x + x^2]_0^t = t + t^2$

(4) $\int_0^t (3 + \frac{1}{2}x)dx = \left[3x + \frac{1}{4}x^2\right]_0^t = 3t + \frac{1}{4}t^2$

< 2 ページ. 面積関数 2 >

問の解答

$$(1) \lim_{h \rightarrow 0} \frac{S(t+h) - S(t)}{h} = t^2$$

$$(2) S'(t) = t^2$$

$$(3) S(t) = \int S'(t) dt = \int t^2 dt = \frac{1}{3}t^3 + C$$

$$(4) C = 0, S(t) = \frac{1}{3}t^3$$

< 3 ページ. 面積関数 3 >

問の解答

「正の数 h に対し,

$$S(t+h) - S(t)$$

は図 2 の斜線部分の面積である。図 2 より

$$\begin{array}{c} \text{長方形 ABCD} \\ \text{の面積} \end{array} \leq S(t+h) - S(t) \leq \begin{array}{c} \text{長方形 ABEF} \\ \text{の面積} \end{array}$$

だから

$$\boxed{t^3 h} \leq S(t+h) - S(t) \leq \boxed{(t+h)^3 h}$$

が成り立つ。すなわち

$$\boxed{t^3} \leq \frac{S(t+h) - S(t)}{h} \leq \boxed{(t+h)^3} \dots \textcircled{1}$$

となる。

ここで、 h を限りなく 0 に近づけたとき、 $(t+h)^3$ は限りなく t^3 に近づく。

従って①式より

$$\lim_{h \rightarrow 0} \frac{S(t+h) - S(t)}{h} = \boxed{t^3}$$

であることがわかる。すなわち $S(t)$ の導関数は $S'(t) = \boxed{t^3}$ である。

ゆえに $S(t)$ は $\boxed{t^3}$ の不定積分

$$S(t) = \int \boxed{t^3} dt = \boxed{\frac{1}{4}t^4} + C$$

である。 $S(0) = 0$ より $C = \boxed{0}$ であるから $S(t) = \boxed{\frac{1}{4}t^4}$ である。」

< 4 ページ. 面積 1 >

問 1 の解答

$$S = S(3) - S(1) = \frac{1}{3} \times 3^3 - \frac{1}{3} \times 1^3 = \frac{26}{3}$$

問 2 の解答

$$S = S(b) - S(a) = \frac{1}{3}b^3 - \frac{1}{3}a^3$$

問 3 の解答

$$S = S(b) - S(a) = [S(x)]_a^b = \left[\frac{1}{3}x^3 \right]_a^b = \int_a^b x^2 dx$$

問 4 の解答

$$S = S(5) - S(1) = \frac{1}{4} \times 5^4 - \frac{1}{4} \times 1^4 = \frac{624}{4} = 156$$

問 5 の解答

$$S = S(b) - S(a) = \frac{1}{4}b^4 - \frac{1}{4}a^4$$

問 6 の解答

$$S = S(b) - S(a) = [S(x)]_a^b = \left[\frac{1}{4}x^4 \right]_a^b = \int_a^b x^3 dx$$

< 5 ページ. 面積 2 >

問の解答

$$(1) S = \int_{-3}^3 x^2 dx = \left[\frac{1}{3} x^3 \right]_{-3}^3 = \frac{27}{3} - \left(-\frac{27}{3} \right) = 18$$

$$(2) S = \int_0^2 (x+1)^2 dx = \int_0^2 (x^2 + 2x + 1) dx = \left[\frac{1}{3} x^3 + x^2 + x \right]_0^2 \\ = \frac{8}{3} + 4 + 2 = \frac{8+18}{3} = \frac{26}{3}$$

< 6 ページ. 面積 3 >

問の解答

$$(1) S = \int_{-1}^1 (-x^2 + 1)dx = \left[-\frac{1}{3}x^3 + x \right]_{-1}^1 = \frac{4}{3}$$

$$(2) S = \int_0^4 (-x^2 + 4x)dx = \left[-\frac{1}{3}x^3 + 2x^2 \right]_0^4 = \frac{32}{3}$$

$$(3) S = \int_2^3 \{-(x-2)(x-3)\}dx = \int_2^3 \{-x^2 + 5x - 6\} = \left[-\frac{x^3}{3} + \frac{5}{2}x^2 - 6x \right]_2^3 = \frac{1}{6}$$

$$(4) y = -x^2 + 2x + 8 = -(x-4)(x+2)$$

$$S = \int_{-2}^4 (-x^2 + 2x + 8)dx = \left[-\frac{x^3}{3} + x^2 + 8x \right]_{-2}^4 = 36$$

< 7 ページ. 面積 4 >

問の解答

$$\begin{cases} y = -x^2 + 2x + 4 & \dots \textcircled{1} \\ y = x^2 & \dots \textcircled{2} \end{cases}$$

$$\textcircled{1} = \textcircled{2} \text{ より}$$

$$x^2 = -x^2 + 2x + 4 \Rightarrow 2x^2 - 2x - 4 = 0$$

$$\Rightarrow x^2 - x - 2 = 0 \Rightarrow (x - 2)(x + 1) = 0 \Rightarrow x = -1, 2$$

$$S = \int_{-1}^2 (-x^2 + 2x + 4) dx - \int_{-1}^2 x^2 dx$$

$$= \int_{-1}^2 (-2x^2 + 2x + 4) dx = \left[-\frac{2}{3}x^3 + x^2 + 4x \right]_{-1}^2$$

$$= 9$$

< 8 ページ. 面積 5 >

問 1 の解答

$$\begin{aligned} S &= \int_a^b \{f(x) + C\} dx - \int_a^b \{g(x) + C\} dx \\ &= \int_a^b \{f(x) - g(x)\} dx \end{aligned}$$

問 2 の解答

$$\begin{aligned} S &= \int_1^2 \{(-x^2 + 3x) - (x^2 - 2x)\} dx \\ &= \int_1^2 \{-2x^2 + 5x\} dx = \left[-\frac{2}{3}x^3 + \frac{5}{2}x^2 \right]_1^2 \\ &= \frac{17}{6} \end{aligned}$$

問 3 の解答

$$\begin{aligned} S &= \int_1^2 \{(-x^2 + 4x - 1) - (x^2 - 3)\} dx = \int_1^2 (-2x^2 + 4x + 2) dx \\ &= \left[-\frac{2}{3}x^3 + 2x^2 + 2x \right]_1^2 \\ &= \frac{10}{3} \end{aligned}$$

< 9 ページ. 面積 6 >

問 1 の解答

$$(1) S = \int_1^2 \{ -(x-1)(x-2) \} dx = \int_1^2 (-x^2 + 3x - 2) dx = \left[-\frac{x^3}{3} + \frac{3}{2}x^2 - 2x \right]_1^2 = \frac{1}{6}$$

$$(2) S = \int_{-3}^0 (-x^2 - 3x) dx = \left[-\frac{1}{3}x^3 - \frac{3}{2}x^2 \right]_{-3}^0 = \frac{9}{2}$$

問 2 の解答

(1) 放物線 $y = x^2$ と直線 $y = -x + 6$ との

交点の x 座標は

$$x^2 = -x + 6 \Rightarrow (x-2)(x+3) = 0$$

より $x = 2, -3$

$$S = \int_{-3}^2 (-x + 6 - x^2) dx$$

$$= \left[-\frac{1}{3}x^3 - \frac{x^2}{2} + 6x \right]_{-3}^2$$

$$= \frac{125}{6}$$

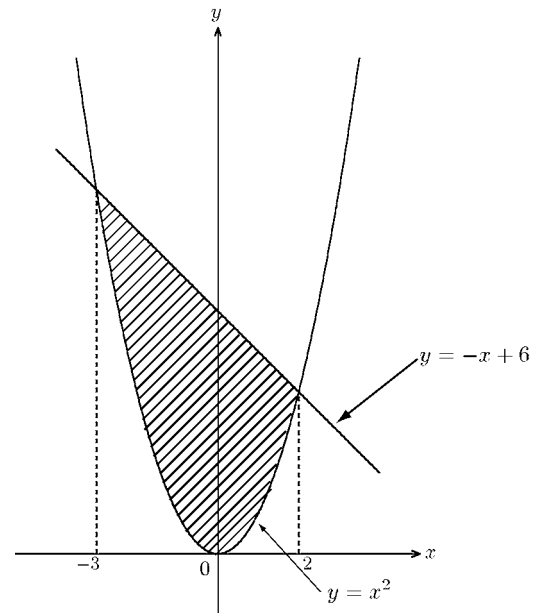

(2) 放物線 $y = -x^2 + 3$ と直線 $y = 2x$ との

交点の x 座標は

$$-x^2 + 3 = 2x \Rightarrow -(x-1)(x+3) = 0$$

より $x = 1, -3$

$$S = \int_{-3}^1 (-x^2 + 3 - 2x) dx$$

$$= \left[-\frac{x^3}{3} - x^2 + 3x \right]_{-3}^1$$

$$= \frac{32}{3}$$

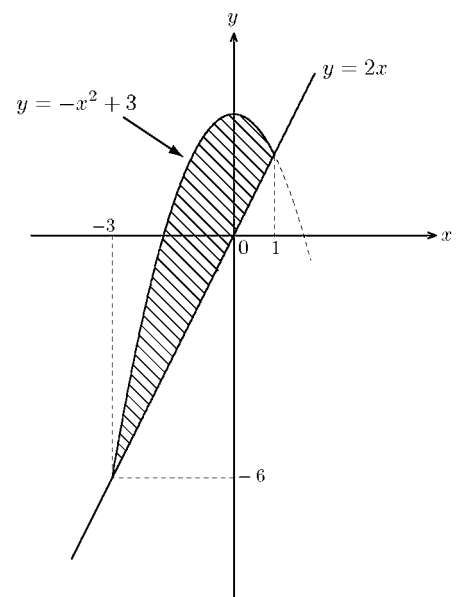

< 10 ページ. 線と面 >

問の解答

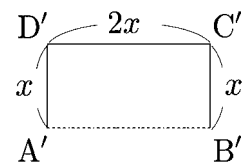
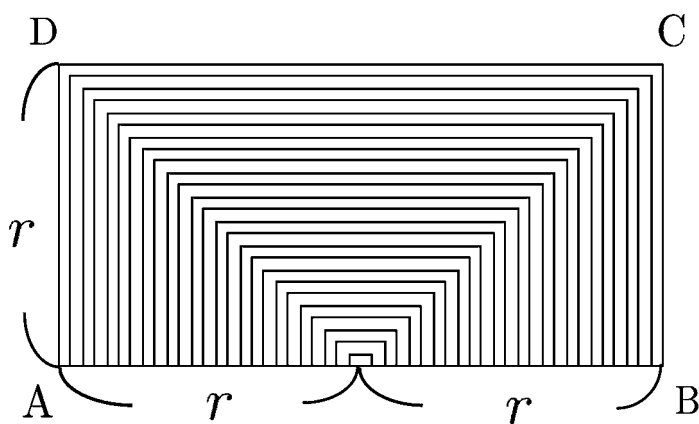

$$\ell(x) = B'C' + C'D' + D'A' = 4x$$

$$\left(\int_0^r \ell(x) dx = \int_0^r 4x dx = [2x^2]_0^r = 2r^2 = S \right)$$

< 11 ページ. 面積の計算 >

問 1 の解答

(1) $S = \int_{-1}^2 (-x^2 + x + 2)dx = \frac{9}{2}$

(2) $S = \int_{-4}^1 (-x^2 - 3x + 4)dx = \frac{125}{6}$

(3) $S = \int_1^3 (-x^2 + 4x - 3)dx = \frac{4}{3}$

(4) $S = \int_{-4}^2 (-x^2 - 2x + 8)dx = 36$

問 2 の解答

(1) 放物線 $y = x^2 - 1$ と直線 $y = 3$ で囲まれた図形

$$\int_{-2}^2 \{3 - (x^2 - 1)\}dx = \int_{-2}^2 (4 - x^2)dx = \left[4x - \frac{x^2}{3}\right]_{-2}^2 = \frac{32}{3}$$

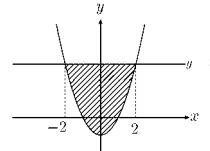
(2) 放物線 $y = -x^2 + 4x$ と x 軸および直線 $x = 2$ で囲まれた左側 ($x \leq 2$) の図形

$$\int_0^2 (-x^2 + 4x)dx = \left[-\frac{x^3}{3} + 2x^2\right]_0^2 = \frac{16}{3}$$

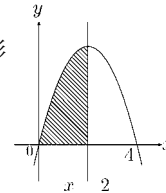
(3) 放物線 $y = x^2 - 3$ と直線 $y = 2x$ で囲まれた図形

$$\int_{-1}^3 \{2x - (x^2 - 3)\}dx = \int_{-1}^3 (-x^2 + 2x + 3)dx = \left[-\frac{x^3}{3} + x^2 + 3x\right]_{-1}^3 = \frac{32}{3}$$

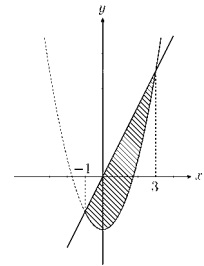
(4) 放物線 $y = x^2 + 2x - 1$ と $y = -x^2 + 2x + 1$ で囲まれた図形

$$\int_{-1}^1 \{(-x^2 + 2x + 1) - (x^2 + 2x - 1)\}dx = \int_{-1}^1 (-2x^2 + 2)dx = \left[-\frac{2}{3}x^3 + 2x\right]_{-1}^1 = \frac{8}{3}$$

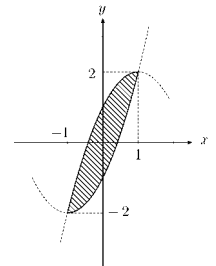

問 3 の解答

(1) $\ell(x) = \frac{1}{8} \times 2\pi x = \frac{\pi}{4}x$

(2) $S = \int_a^b \ell(x)dx$

(3) $S = \int_a^b \frac{\pi}{4}x dx = \left[\frac{\pi}{8}x^2\right]_a^b = \frac{\pi}{8}b^2 - \frac{\pi}{8}a^2$

問 3 の別解

(3) 半径 x , 中心角 45° の扇形の面積を $S(x)$ とする。 $S(x)$ は円の面積 πx^2 の $\frac{1}{8}$ であるから, $S(x) = \frac{\pi x^2}{8}$ である。よって

$$S = S(b) - S(a) = \frac{\pi b^2}{8} - \frac{\pi a^2}{8}$$

(2) 上記 (3) の結果より

$$S = S(b) - S(a) = [S(x)]_a^b = \left[\frac{\pi x^2}{8}\right]_a^b = \int_a^b \frac{\pi}{4}x dx = \int_a^b \ell(x)dx$$

< 12 ページ. 累乗の指数 >

問 1 の解答

$$1 \text{ 京} = 10^4 \text{ 兆} = 10^4 \times 10^{12} = 10^{16}$$

問 2 の解答

$$1 \text{ メガ} = 1000 \text{ キロ} = 10^3 \times 10^3 = 10^6$$

$$1 \text{ ギガ} = 10^3 \text{ メガ} = 10^9$$

$$1 \text{ テラ} = 10^3 \text{ ギガ} = 10^{12}$$

問 3 の解答

$$(1) 10^4 \times 10^6 = 10^{10}$$

$$(2) 10^8 \times 10^9 = 10^{17}$$

$$(3) 10^{15} \times 10^{27} = 10^{42}$$

$$(4) 10^5 \div 10^2 = 10^3$$

$$(5) 10^9 \div 10^5 = 10^4$$

$$(6) 10^{23} \div 10^{15} = 10^8$$

< 13 ページ. 指数法則 >

問 1 の解答

(1) $a^2 \times a^5 = a^7$

(2) $a^6 \times a^3 = a^9$

(3) $a^8 \div a^3 = a^5$

問 2 の解答

(1) $(a^5)^3 = a^{15}$

(2) $(ab^2)^3 = a^3b^6$

(3) $(a^2b^3)^4 = a^8b^{12}$

問 3 の解答

(1) $a^4 \times a^5 \times a^3 = a^{4+5+3} = a^{12}$

(2) $(a^3)^2 \times a^4 = a^{6+4} = a^{10}$

(3) $a^{10} \div (a^3)^3 = a$

(4) $(a^2b)^3 \times (ab^2)^2 = a^6b^3 \times a^2b^4 = a^8b^7$

< 14 ページ. 負の指数 >

問の解答

(1) $2^0 = 1$

(2) $1^{-1} = 1$

(3) $2^{-5} = \frac{1}{32}$

(4) $3^0 = 1$

(5) $3^{-2} = \frac{1}{9}$

(6) $4^{-3} = \frac{1}{64}$

(7) $(2^{-3})^2 = \frac{1}{64}$

(8) $(3^2)^{-2} = \frac{1}{81}$

(9) $(2^2)^{-3} = \frac{1}{64}$

< 15 ページ. 整数指数 1 >

問 1 の解答

(1) $a^3 \times a^{-5} = a^{-2}$

(2) $a^{-3} \times a^2 = a^{-1}$

(3) $a^4 \times a^{-7} = a^{-3}$

(4) $a^{-8} \times a^5 = a^{-3}$

(5) $a^{-3} \times a^{-4} = a^{-7}$

(6) $a^{-5} \times a^{-6} = a^{-11}$

問 2 の解答

(1) $a^4 \div a^6 = a^{-2}$

(2) $a^3 \div a^{-2} = a^5$

(3) $a^{-2} \div a^3 = a^{-5}$

(4) $a^4 \div a^{-5} = a^9$

(5) $a^{-7} \div a^{-4} = a^{-3}$

(6) $a^{-7} \div a^{-9} = a^2$

< 16 ページ. 整数指数 2 >

問 1 の解答

(1) $(a^4)^{-2} = a^{-8}$

(2) $(a^{-2})^4 = a^{-8}$

(3) $(a^{-5})^{-2} = a^{-10}$

(4) $(a^{-3})^4 = a^{-12}$

(5) $(a^{-3})^{-3} = a^9$

(6) $(a^{-6})^{-5} = a^{30}$

問 2 の解答

(1) $(ab)^4 = a^4b^4$

(2) $(a^2b)^3 = a^6b^3$

(3) $(ab^{-1})^2 = a^2b^{-2}$

(4) $(ab)^{-3} = a^{-3}b^{-3}$

(5) $(a^{-1}b^2)^3 = a^{-3}b^6$

(6) $(a^{-2}b^3)^{-2} = a^4b^{-6}$

(7) $(ab^2)^{-3} \times (a^2b)^2 = a^{-3}b^{-6} \times a^4b^2 = ab^{-4}$

(8) $(a^3b^2)^3 \div (ab^3)^4 = (a^9b^6) \div (a^4b^{12}) = a^5b^{-6}$

< 17 ページ. 整数指数 3 >

問 1 の解答

(1) $10^3 \times 10^{-20} = 10^{-17}$ (2) $10^5 \div 10^{-6} = 10^{11}$ (3) $10^{-7} \div 10^{-8} = 10$

(4) $1 \div 10^{-20} = 10^{20}$ (5) $(10^{-2})^3 = 10^{-6}$ (6) $(10^{-3})^{-1} = 10^3$

問 2 の解答

(1) $a^{-3} \times a^{-1} = a^{-4}$ (2) $a^{-3} \times a^{-5} = a^{-8}$ (3) $a^4 \div a^{-2} = a^6$

(4) $a^{-4} \div a^{-2} = a^{-2}$ (5) $(a^3)^{-3} = a^{-9}$ (6) $(a^{-4})^{-1} = a^4$

問 3 の解答

(1) $4^7 \times 4^{-4} = 4^3 = 64$ (2) $5^{-7} \div 5^{-6} = 5^{-1} = \frac{1}{5}$

(3) $2^{-2} \div 2^{-5} = 2^3 = 8$ (4) $(3^{-2})^{-2} = 3^4 = 81$

問 4 の解答

(1) $a^3 \times a^{-6} = \frac{1}{a^3}$ (2) $a^{-4} \div a^{-10} = a^6$ (3) $a^{-5} \div a^{-5} = 1$

(4) $(ab^{-1})^2 = \frac{a^2}{b^2}$ (5) $(a^{-1}b)^{-3} = \frac{a^3}{b^3}$ (6) $(a^{-2}b^3)^2 = \frac{b^6}{a^4}$

< 18 ページ. 整数指数 4 >

問 1 の解答

$$1 \text{ マイクロ} = 10^{-3} \text{ ミリ} = 10^{-3} \times 10^{-3} = 10^{-6}$$

$$1 \text{ ナノ} = 10^{-3} \text{ マイクロ} = 10^{-3} \times 10^{-6} = 10^{-9}$$

$$1 \text{ ピコ} = 10^{-3} \text{ ナノ} = 10^{-3} \times 10^{-9} = 10^{-12}$$

問 2 の解答

$$(1) 43000 = 4.3 \times 10^4$$

$$(2) 2730000000 = 2.73 \times 10^9$$

$$(3) 0.000045 = 4.5 \times 10^{-5}$$

$$(4) 0.000000000000368 = 3.68 \times 10^{-13}$$

問 3 の解答

$$(1) (1.5 \times 10^4) \times (4 \times 10^8) = 6.0 \times 10^{12}$$

$$(2) (4.2 \times 10^{-2}) \times (2.5 \times 10^{-7}) = 4.2 \times 2.5 \times 10^{-9} = 1.05 \times 10^{-8}$$

$$(3) (6.8 \times 10^{-2}) \times (5 \times 10^3) = \frac{6.8}{5} \times 10^{-5} = 1.36 \times 10^{-5}$$

$$(4) (4.8 \times 10^2) \times (1.2 \times 10^{-10}) = \frac{4.8}{1.2} \times 10^{12} = 4.0 \times 10^{12}$$

$$(5) 1 \div (2.5 \times 10^{-15}) = \frac{1}{2.5} \times 10^{15} = \frac{4}{10} \times 10^{15} = 0.4 \times 10^{15} = 4 \times 10^{14}$$

問 4 の解答

$$1 \div (4.5 \times 10^{-23}) = \frac{1}{4.5} \times 10^{23} = \frac{2}{9} \times 10^{23}$$

$$= 0.222 \times 10^{23}$$

$$\doteq 2.2 \times 10^{22}$$

< 19 ページ. 累乗根 1 >

問の解答

(1) $\sqrt{169} = 13$

(2) $\sqrt[3]{8} = 2$

(3) $\sqrt[3]{125} = 5$

(4) $\sqrt[4]{256} = 4$

(5) $\sqrt[4]{\frac{81}{625}} = \frac{3}{5}$

(6) $\sqrt[5]{3125} = 5$

< 20 ページ. 累乗根 2 >

問の解答

$$(1) \sqrt[3]{3} \times \sqrt[3]{5} = \sqrt[3]{15}$$

$$(2) \sqrt[4]{2} \times \sqrt[4]{4} = \sqrt[4]{8}$$

$$(3) \frac{\sqrt[3]{3}}{\sqrt[3]{15}} = \sqrt[3]{\frac{1}{5}} \left(= \frac{1}{\sqrt[3]{5}} \right)$$

$$(4) \frac{\sqrt[5]{128}}{\sqrt[5]{4}} = \sqrt[5]{\frac{128}{4}} = \sqrt[5]{32} = 2$$

< 21 ページ. 累乗根 3 >

問 1 の解答

(1) $\sqrt[3]{54} = 3\sqrt[3]{2}$

(2) $\sqrt[4]{112} = 2\sqrt[4]{7}$

(3) $\sqrt[5]{64} = 2\sqrt[5]{2}$

問 2 の解答

(1) $(\sqrt[4]{25})^2 = 5$

(2) $(\sqrt[6]{4})^3 = 2$

(3) $\sqrt[4]{16^2} = 4$

(4) $\sqrt[3]{27^2} = 9$

< 22 ページ. 分数指数 1 >

問 1 の解答

(1) $121^{\frac{1}{2}} = 11$

(2) $27^{\frac{1}{3}} = 3$

(3) $25^{\frac{3}{2}} = 125$

(4) $343^{\frac{2}{3}} = 49$

(5) $81^{\frac{5}{4}} = 243$

(6) $32^{\frac{4}{5}} = 16$

(7) $16^{-\frac{1}{2}} = \frac{1}{\sqrt{16}} = \frac{1}{4}$

(8) $27^{-\frac{4}{3}} = \frac{1}{81}$

(9) $64^{-\frac{2}{3}} = \frac{1}{16}$

問 2 の解答

(1) $\sqrt[3]{a} = a^{\frac{1}{3}}$

(2) $\sqrt[3]{a^2} = a^{\frac{2}{3}}$

(3) $(\sqrt[4]{a})^5 = a^{\frac{5}{4}}$

(4) $(\sqrt[4]{a})^{-3} = a^{-\frac{3}{4}}$

< 23 ページ. 分数指数 2 >

問 1 の解答

(1) $\sqrt[6]{4^3} = 2$

(2) $\sqrt[12]{7^4} = \sqrt[3]{7}$

(3) $\sqrt[3]{5^9} = 125$

(4) $\sqrt[6]{27^4} = 9$

問 2 の解答

(1) $\sqrt[2]{10} \times \sqrt[4]{100} = 10$

(2) $\frac{\sqrt[3]{9}}{\sqrt[6]{9}} = \frac{\sqrt[3]{9}}{\sqrt[3]{9}} = \sqrt[3]{3}$

(3) $\sqrt{\sqrt[3]{9}} = \sqrt[3]{3}$

(4) $\left(\sqrt[3]{\sqrt{27}}\right)^2 = \left(\left(\left(3^3\right)^{\frac{1}{2}}\right)^{\frac{1}{3}}\right)^2 = 3^{3 \times \frac{1}{2} \times \frac{1}{3} \times 2} = 3$

< 24 ページ. 指数法則の拡張 >

問 1 の解答

正の数 a と b , および有理数 p と q に対して

$$1^\circ : a^p \times a^q = a^{\boxed{p+q}}, \quad 2^\circ : a^p \div a^q = a^{\boxed{p-q}}$$

$$3^\circ : (a^p)^q = a^{\boxed{pq}}, \quad 4^\circ : (ab)^p = a^p b^p$$

問 2 の解答

$$(1) \sqrt[4]{a} \times \sqrt[4]{a^3} = a$$

$$(2) \sqrt[3]{a^4} \div \sqrt[3]{a} = a$$

$$(3) (\sqrt[3]{a})^4 \times \sqrt[3]{a^2} = a^{\frac{4}{3} + \frac{2}{3}} = a^2$$

$$(4) \sqrt[3]{a^7} \div (\sqrt[3]{a})^4 = a^{\frac{7}{3} - \frac{4}{3}} = a$$

$$(5) (\sqrt[4]{a})^{\frac{8}{3}} = a^{\frac{1}{4} \times \frac{8}{3}} = a^{\frac{2}{3}} = \sqrt[3]{a^2}$$

$$(6) \left(\sqrt[5]{\sqrt[4]{a^{-3}}} \right)^{-2} = \left(\left((a^{-3})^{\frac{1}{4}} \right)^{\frac{1}{5}} \right)^{-2} = a^{-3 \times \frac{1}{4} \times \frac{1}{5} \times (-2)} = a^{\frac{3}{10}} = \sqrt[10]{a^3}$$

問 3 の解答

$$(1) (3^3 \times 5^2)^{\frac{1}{7}} \times (3^4 \times 5^5)^{\frac{1}{7}} = 3^{\frac{3}{7} + \frac{4}{7}} \times 5^{\frac{2}{7} + \frac{5}{7}} = 3 \times 5 = 15$$

$$(2) \sqrt[4]{18} \times \sqrt[4]{72} = (2 \times 3^2)^{\frac{1}{4}} \times (2^3 \times 3^2)^{\frac{1}{4}} = (2^4)^{\frac{1}{4}} \times (3^4)^{\frac{1}{4}} = 6$$

< 25 ページ. 指数関数 >

問の解答

(1) $y = 2^x$

x	-2	-1	0	$\frac{1}{2}$	1	2
y	$\frac{1}{4}$	$\frac{1}{2}$	1	$\sqrt{2}$	2	4

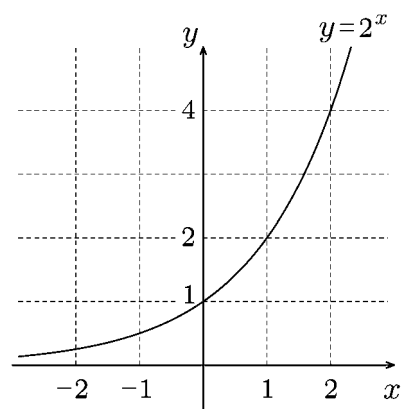

(2) $y = 4^x$

x	-1	$-\frac{1}{2}$	0	$\frac{1}{2}$	1	$\frac{3}{2}$
y	$\frac{1}{4}$	$\frac{1}{2}$	1	2	4	8

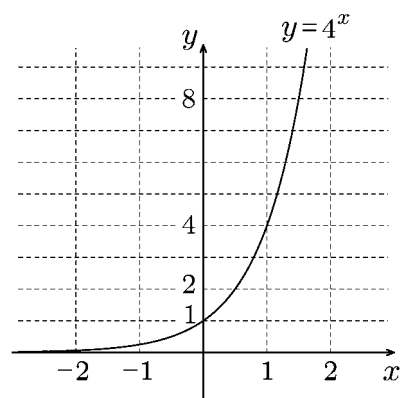

(3) $y = \left(\frac{1}{2}\right)^x$

x	-2	-1	0	1	2
y	4	2	1	$\frac{1}{2}$	$\frac{1}{4}$

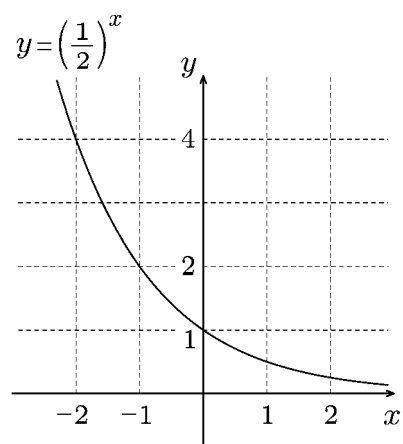

< 26 ページ. 指数方程式 >

問の解答

(1) $x = 0$

(2) $x = 1$

(3) $x = 2$

(4) $x = -1$

(5) $x = \frac{1}{2}$

(6) $x = 0$

(7) $x = 2$

(8) $x = \frac{1}{3}$

(9) $x = -1$

(10) $x = -2$

(11) $x = 0$

(12) $x = 2$

(13) $x = 5$

(14) $x = \frac{1}{4}$

(15) $x = \frac{3}{2}$

(16) $x = -1$

(17) $x = -3$

(18) $x = -2$

(19) $x = -\frac{1}{2}$

(20) $x = 0$

(21) $x = 1$

(22) $x = 3$

(23) $x = 2$

(24) $x = -1$

(25) $x = -2$

(26) $x = -\frac{1}{2}$

(27) $x = 0$

(28) $x = 2$

(29) $x = \frac{1}{2}$

(30) $x = \frac{3}{2}$

(31) $x = -1$

(32) $x = \frac{1}{4}$

< 27 ページ. 対数 1 >

問 1 の解答

(1) $\frac{1}{2} = \log_2 \sqrt{2}$

(2) $-1 = \log_5 \frac{1}{5}$

(3) $27 = 3^3$

(4) $27 = 9^{\frac{3}{2}}$

問 2 の解答

(1) $\log_2 32 = 5$

(2) $\log_3 243 = 5$

(3) $\log_{10} 1000 = 3$

(4) $\log_5 625 = 4$

(5) $\log_2 \frac{1}{8} = -3$

(6) $\log_3 \sqrt{3} = \frac{1}{2}$

< 28 ページ. 対数 2 >

問 1 の解答

- | | | |
|--|--|-------------------------------|
| (1) $\log_2 64 = 6$ | (2) $\log_2 \sqrt{2} = \frac{1}{2}$ | (3) $\log_2 0.5 = -1$ |
| (4) $\log_2(2\sqrt{2}) = \frac{3}{2}$ | (5) $\log_4 64 = 3$ | (6) $\log_4 1 = 0$ |
| (7) $\log_6 \sqrt[3]{6} = \frac{1}{3}$ | (8) $\log_5 0.2 = -1$ | (9) $\log_{10} 0.01 = -2$ |
| (10) $\log_7 \sqrt[3]{49} = \frac{2}{3}$ | (11) $\log_2 \left(\frac{1}{\sqrt{2}} \right) = -\frac{1}{2}$ | (12) $\log_4 8 = \frac{3}{2}$ |

問 2 の解答

$$\log_2(M \times N) = \log_2(2^\alpha \times 2^\beta) = \log_2(2^{\alpha+\beta}) = \alpha + \beta$$

$$\log_2 M + \log_2 N = \log_2 2^\alpha + \log_2 2^\beta = \alpha + \beta$$

$$\text{よって } \log_2(M \times N) = \log_2 M + \log_2 N$$

< 29 ページ. 対数 3 >

問 1 の解答

$$\log_2\left(\frac{M}{N}\right) = \log_2\left(\frac{2^\alpha}{2^\beta}\right) = \log_2(2^{\alpha-\beta}) = \alpha - \beta$$

$$\log_2 M - \log_2 N = \log_2(2^\alpha) - \log_2(2^\beta) = \alpha - \beta$$

$$\text{よ} \ddot{\text{r}} \log_2\left(\frac{M}{N}\right) = \log_2 M - \log_2 N$$

問 2 の解答

$$\log_2(M^r) = \log_2\left((2^\alpha)^r\right) = \log_2(2^{\alpha r}) = \alpha r$$

$$r \times \log_2 M = r \times \log_2(2^\alpha) = r \times \alpha = \alpha r$$

$$\text{よ} \ddot{\text{t}} \log_2(M^r) = r \times \log_2 M$$

< 30 ページ. 対数 4 >

問 1 の解答

$$\log_a\left(\frac{M}{N}\right) = \log_a M - \log_a N$$

問 2 の解答

$$\log_a(M^r) = r \times \log_a M$$

問 3 の解答

$$(1) \log_2 12 + \log_2\left(\frac{1}{3}\right) = \log_2 4 = 2$$

$$(2) \log_3 108 - \log_3 4 = \log_3 \frac{108}{4} = \log_3 27 = 3$$

$$\begin{aligned} (3) \log_6 12 + \log_6 2 + 2 \log_6 3 &= \log_6(12 \times 2 \times 3^2) \\ &= \log_6(2^3 \times 3^3) \\ &= \log_6(6^3) = 3 \end{aligned}$$

$$(4) \log_{10} 4 + \log_{10} 25 + \log_{10} 0.1 = \log_{10}\left(\frac{4 \times 25}{0.1}\right) = \log_{10}\left(\frac{100 \times 10}{1}\right) = 3$$

< 31 ページ. 底の変換 >

問 1 の解答

$$(1) \log_8 16 = \frac{\log_2 16}{\log_2 8} = \frac{4}{3}$$

$$(2) \log_{16} 64 = \frac{\log_4 64}{\log_4 16} = \frac{3}{2}$$

$$(3) \log_{27} 81 = \frac{\log_3 81}{\log_3 27} = \frac{4}{3}$$

$$(4) \log_8 2 = \frac{\log_2 2}{\log_2 8} = \frac{1}{3}$$

$$(5) \log_4 \sqrt{2} = \frac{\log_2 \sqrt{2}}{\log_2 4} = \frac{\frac{1}{2}}{2} = \frac{1}{4}$$

$$(6) \log_{27} \sqrt{3} = \frac{\log_3 \sqrt{3}}{\log_3 27} = \frac{\frac{1}{2}}{3} = \frac{1}{6}$$

問 2 の解答

$$\log_a b = \frac{\log_b b}{\log_b a} = \frac{1}{\log_b a}$$

問 3 の解答

$$(1) \log_4 32 + \log_{16} 64 = \frac{\log_2 32}{\log_2 4} + \frac{\log_4 64}{\log_4 16} = \frac{5}{2} + \frac{3}{2} = \frac{8}{2} = 4$$

$$(2) (\log_3 4) \times (\log_4 9) = \log_3 4 \times \frac{\log_3 9}{\log_3 4} = 2$$

$$(3) (\log_2 3) \times (\log_3 4) \times (\log_4 2) = \log_2 3 \times \frac{\log_2 4}{\log_2 3} \times \frac{1}{\log_2 4} = 1$$

< 32 ページ. 対数関数 >

問の解答

(1) $y = \log_{10} x \quad (x > 0)$

x	0.1	1	$\sqrt{10}$	10
y	-1	0	$\frac{1}{2}$	1

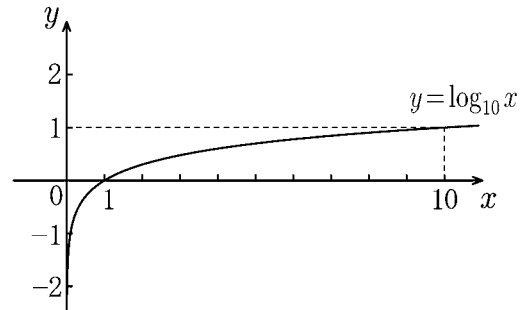
注) $\sqrt{10} \doteq 3.16$ 

(2) $y = \log_2 x \quad (x > 0)$

x	$\frac{1}{4}$	$\frac{1}{2}$	1	2	4
y	-2	-1	0	1	2

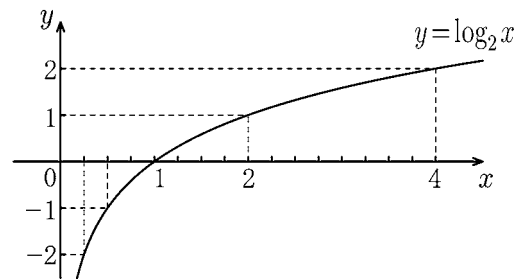

(3) $y = \log_{\frac{1}{2}} x \quad (x > 0)$

x	$\frac{1}{4}$	$\frac{1}{2}$	1	2	4
y	2	1	0	-1	-2

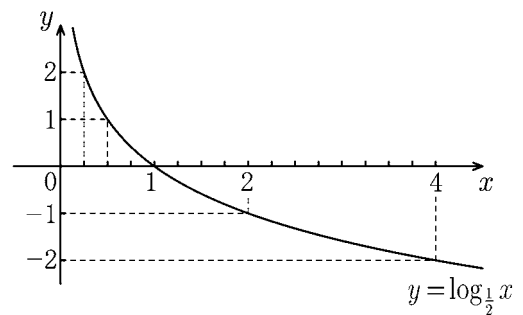

< 33 ページ. 常用対数 1 >

問 1 の解答

$$(1) \log_{10}(1430) = \log_{10} 1.43 + \log_{10} 1000 = 0.1553 + 3 = 3.1553$$

$$(2) \log_{10}(203000) = \log_{10} 2.03 + \log_{10} 100000 = 0.3075 + 5 = 5.3075$$

$$(3) \log_{10} 0.00302 = \log_{10}(3.02 \times 10^{-3}) = 0.4800 - 3 = -2.5200$$

問 2 の解答

$$x = 3^{50} \text{ とおくと}$$

$$\log_{10} x = \log_{10} 3^{50} = 50 \times \log_{10} 3 = 50 \times 0.4771 = 23.855$$

$$\Rightarrow x = 10^{23.855} \Rightarrow 10^{23} < x < 10^{24}$$

(答) 24 桁

< 34 ページ. 常用対数 2 >

問 1 の解答

$$\begin{aligned}\log_{10} \sqrt[4]{5} &= \frac{1}{4} \log_{10} 5 = \frac{1}{4} \log_{10} \frac{10}{2} = \frac{1}{4} (\log_{10} 10 - \log_{10} 2) \\ &= \frac{1}{4} (1 - 0.301) = \frac{1}{4} \times 0.699 = 0.17475\end{aligned}$$

問 2 の解答

$$\log_2 3 = \frac{\log_{10} 3}{\log_{10} 2} = \frac{0.4771}{0.301} \doteq 1.5850$$

問 3 の解答

$$\begin{aligned}x = 0.5^{20} &\Rightarrow \log_{10} x = 20 \log_{10} 0.5 = 20 \times \log_{10} \frac{1}{2} = -20 \times \log_{10} 2 = -20 \times 0.301 = -6.02 \\ x = 10^{-6.02} &\Rightarrow 10^{-7} < x < 10^{-6} \Rightarrow 0.0000001 < x < 0.000001\end{aligned}$$

(答) 小数第 7 位

問 4 の解答

時間	…	倍率
30 分	…	$2 = 2^1$
1 時間	…	$4 = 2^2$
1.5 時間	…	$8 = 2^3$
2 時間	…	$16 = 2^4$
2.5 時間	…	$32 = 2^5$
3 時間	…	$64 = 2^6$
x 時間	…	2^{2x}

より求める時間を x とすると

$$2^{2x} = 1000$$

$$\log_{10}(2^{2x}) = \log_{10} 1000$$

$$2x \log_{10} 2 = 3$$

$$x = \frac{3}{2 \log_{10} 2} = \frac{3}{0.602} = \frac{3000}{602} = 4.983$$

$$x = 4.983\text{h}$$

$$0.983\text{h} = 0.983 \times 60\text{min} = 58.98\text{min}$$

(答) 約 4 時間 59 分後

< 35 ページ. 指数・対数の練習 1 >

問 1 の解答

(1) $27^{-\frac{2}{3}} = 3^{-2} = \frac{1}{9}$

(2) $(0.25)^{0.5} = \left(\frac{1}{4}\right)^{\frac{1}{2}} = \frac{1}{2}$

(3) $\frac{1}{(0.2)^{-2}} = \frac{1}{\left(\frac{1}{5}\right)^{-2}} = \frac{1}{5^2} = \frac{1}{25}$

(4) $\log_9 27 = \frac{3}{2}$

(5) $\log_{\frac{1}{2}} 16 = \frac{4}{-1} = -4$

(6) $\log_{0.2} 125 = \log_{\frac{1}{5}} 125 = \frac{\log_5 125}{\log_5 \frac{1}{5}} = \frac{3}{-1} = -3$

問 2 の解答

(1) $36^{1.5} \times 32^{-0.2} = (2^2 \times 3^2)^{\frac{3}{2}} \times (2^5)^{-\frac{1}{5}} = 2^3 \times 3^3 \times 2^{-1} = 108$

(2) $\frac{\left(\frac{1}{4}\right)^2 \times \left(\frac{1}{8}\right)^{-4} \div 16}{\left(\frac{1}{2}\right)^3} = (2^{-2})^2 \times (2^{-3})^{-4} \div (2^4 \times 2^{-3}) = 128$

(3) $(a^3 b)^{\frac{1}{6}} \times (ab^2)^{\frac{2}{3}} \div (ab^{-3})^{\frac{1}{6}} = (a^{\frac{1}{2}} b^{\frac{1}{6}}) \times (a^{\frac{2}{3}} b^{\frac{4}{3}}) \div (a^{\frac{1}{6}} b^{-\frac{1}{2}}) = a^{\frac{1}{2} + \frac{2}{3} - \frac{1}{6}} \times b^{\frac{1}{6} + \frac{4}{3} + \frac{1}{2}} = ab^2$

(4) $\sqrt[6]{a^5 b} \times \sqrt{ab} \div \sqrt[3]{a^4 b^{-1}} = a^{\frac{5}{6}} b^{\frac{1}{6}} \times a^{\frac{1}{2}} b^{\frac{1}{2}} \div a^{\frac{4}{3}} b^{-\frac{1}{3}} = a^{\frac{5}{6} + \frac{1}{2} - \frac{4}{3}} b^{\frac{1}{6} + \frac{1}{2} + \frac{1}{3}} = b$

(5) $108^{0.2} \times 72^{0.2} = (2^2 \times 3^3)^{\frac{1}{5}} \times (2^3 \times 3^2)^{\frac{1}{5}} = 2 \times 3 = 6$

(6) $\sqrt[14]{800} \times \sqrt[14]{12500} = (2^5 5^2)^{\frac{1}{14}} \times (2^2 \times 5^5)^{\frac{1}{14}} = \sqrt{10}$

問 3 の解答

(1) $\log_5 20 + \log_5 100 - 2 \log_5 4 = \log_5 \left(\frac{20 \times 100}{16}\right) = 3$

(2) $4 \log_3 \sqrt{3} - \frac{1}{2} \log_3 2 + \log_3 \frac{\sqrt{2}}{3} = \log_3 \left(\frac{9 \times \sqrt{2}}{\sqrt{2} \times 3}\right) = 1$

(3) $\frac{1}{2} \log_5 3 + 3 \log_5 \sqrt{2} - \log_5 \sqrt{24} = \log_5 \left(\frac{\sqrt{3} \times 2\sqrt{2}}{\sqrt{24}}\right) = \log_5 1 = 0$

(4) $(\log_4 5)(\log_5 6)(\log_6 8) = \frac{\log_2 5}{\log_2 4} \times \frac{\log_2 6}{\log_2 5} \times \frac{\log_2 8}{\log_2 6} = \frac{\log_2 8}{\log_2 4} = \frac{3}{2}$

$$(5) \log_3 \frac{3}{2} + \log_9 \frac{81}{4} + \log_{27} \frac{64}{27} = \log_3 \frac{3}{2} + \frac{\log_3 \frac{81}{4}}{\log_3 9} + \frac{\log_3 \frac{64}{27}}{\log_3 27}$$

$$= \log_3 \frac{3}{2} + \frac{1}{2} \log_3 \left(\frac{81}{4}\right) + \frac{1}{3} \log_3 \left(\frac{64}{27}\right) = \log_3 \left(\frac{3}{2} \times \frac{9}{2} \times \frac{4}{3}\right)$$

$$= \log_3 9 = 2$$

$$(6) (\log_2 3 + \log_4 9)(\log_3 4 + \log_9 2) = \log_2 3 \log_3 4 + \log_2 3 \log_9 2$$

$$+ \log_4 9 \log_3 4 + \log_4 9 \log_9 2$$

$$= \log_2 4 + \log_2 3 \times \frac{\log_3 2}{\log_3 9} + \log_3 9 + \log_4 2 = 5$$

< 36 ページ. 指数・対数の練習 2 >

問 1 の解答

(1) $x = 5.5 \left(= \frac{11}{2} \right)$

(2) $x = -\frac{1}{6}$

(3) $x = 2$

(4) $x = 6$

問 2 の解答

(1) $x > -\frac{1}{2}$

(2) $\frac{5}{2} < x \leq \frac{11}{4}$

問 3 の解答

(1) $(0.9)^{0.5} < 1 < (0.9)^{-\frac{1}{3}}$

(2) $3 < \frac{1}{2} \log_2 81 < \log_2 10$

(3) $\sqrt[6]{7} < \sqrt{2} < \sqrt[3]{3}$

(4) $\sqrt[3]{10} < \sqrt{7} < 3$ より

$\log_8 10 < \log_4 7 < \log_2 3$

問 4 の解答

(1) $\log_{10} \sqrt{\frac{8}{9}} = \frac{1}{2} \log_{10} 8 - \frac{1}{2} \log_{10} 9 = \frac{3}{2}a - b$

(2) $\log_2 6 = \frac{\log_{10} 6}{\log_{10} 2} = \frac{a+b}{a} \left(= 1 + \frac{b}{a} \right)$

(3) $\log_9 \sqrt{5} = \frac{\log_{10} \sqrt{5}}{\log_{10} 9} = \frac{\log_{10} 10 - \log_{10} 2}{4 \log_{10} 3} = \frac{1-a}{4b}$

問 5 の解答

(1) $x = 6^{40} \Rightarrow \log_{10} x = 40(\log_{10} 2 + \log_{10} 3) = 31.124$

$\Rightarrow x = 10^{31.124}$ (答) 32 桁

(2) $x = \left(\frac{1}{12} \right)^{10} \Rightarrow \log_{10} x = 10 \log_{10} \frac{1}{12} = 10(-2 \log_{10} 2 - \log_{10} 3) = -10.791$

$x = 10^{-10.791}$ (答) 少数第 11 位

問 6 の解答

x 時間後に 10 万倍になるとすると

$2^{\frac{x}{3}} = 100000 = 10^5$

$\log_{10} 2^{\frac{x}{3}} = 5$

$x = \frac{15}{\log_{10} 2} = \frac{15000}{301} = 49.8338$

$0.834\text{h} = 50.04\text{min}$

(答) 約 49 時間 50 分

< 37 ページ. 三角関数の復習 1 >

問 1 の解答

$$1 + \tan^2 \theta = \frac{1}{\cos^2 \theta}$$

問 2 の解答

$$\cos \theta = -\sqrt{1 - \sin^2 \theta}$$

問 3 の解答

$$\begin{aligned} (\sin \theta + \cos \theta)^2 + (\sin \theta - \cos \theta)^2 &= \sin^2 \theta + 2 \sin \theta \cos \theta + \cos^2 \theta \\ &\quad + \sin^2 \theta - 2 \sin \theta \cos \theta + \cos^2 \theta \\ &= 2(\sin^2 \theta + \cos^2 \theta) \\ &= 2 \end{aligned}$$

< 38 ページ. 三角関数の復習 2 >

問 1 の解答

$$a^2 = b^2 + c^2$$

問 2 の解答

$$b^2 = a^2 + c^2 - 2ac \cos 60^\circ = a^2 + c^2 - ac$$

問 3 の解答

$$c^2 = a^2 + b^2 - 2ab \cos 120^\circ = a^2 + b^2 + ab$$

問 4 の解答

角度 θ	-90°	-60°	-45°	-30°	0°	30°	45°	60°	90°	120°	135°	150°	180°
$\sin \theta$	-1	$-\frac{\sqrt{3}}{2}$	$-\frac{\sqrt{2}}{2}$	$-\frac{1}{2}$	0	$\frac{1}{2}$	$\frac{\sqrt{2}}{2}$	$\frac{\sqrt{3}}{2}$	1	$\frac{\sqrt{3}}{2}$	$\frac{\sqrt{2}}{2}$	$\frac{1}{2}$	0
$\cos \theta$	0	$\frac{1}{2}$	$\frac{\sqrt{2}}{2}$	$\frac{\sqrt{3}}{2}$	1	$\frac{\sqrt{3}}{2}$	$\frac{\sqrt{2}}{2}$	$\frac{1}{2}$	0	$-\frac{1}{2}$	$-\frac{\sqrt{2}}{2}$	$-\frac{\sqrt{3}}{2}$	-1
$\tan \theta$	\times	$-\sqrt{3}$	-1	$-\frac{\sqrt{3}}{3}$	0	$\frac{\sqrt{3}}{3}$	1	$\sqrt{3}$	\times	$-\sqrt{3}$	-1	$-\frac{\sqrt{3}}{3}$	0

角度 θ	180°	210°	225°	240°	270°	300°	315°	330°	360°	390°	405°	420°	450°
$\sin \theta$	0	$-\frac{1}{2}$	$-\frac{\sqrt{2}}{2}$	$-\frac{\sqrt{3}}{2}$	-1	$-\frac{\sqrt{3}}{2}$	$-\frac{\sqrt{2}}{2}$	$-\frac{1}{2}$	0	$\frac{1}{2}$	$\frac{\sqrt{2}}{2}$	$\frac{\sqrt{3}}{2}$	1
$\cos \theta$	-1	$-\frac{\sqrt{3}}{2}$	$-\frac{\sqrt{2}}{2}$	$-\frac{1}{2}$	0	$\frac{1}{2}$	$\frac{\sqrt{2}}{2}$	$\frac{\sqrt{3}}{2}$	1	$\frac{\sqrt{3}}{2}$	$\frac{\sqrt{2}}{2}$	$\frac{1}{2}$	0
$\tan \theta$	0	$\frac{\sqrt{3}}{3}$	1	$\sqrt{3}$	\times	$-\sqrt{3}$	-1	$-\frac{\sqrt{3}}{3}$	0	$\frac{\sqrt{3}}{3}$	1	$\sqrt{3}$	\times

< 39 ページ. 平面座標の三角関数表示 >

問の解答

$$(1) (\sqrt{3}, 1) = (2 \cos 30^\circ, 2 \sin 30^\circ)$$

$$(2) (-2, 2) = (2\sqrt{2} \cos 135^\circ, 2\sqrt{2} \sin 135^\circ)$$

$$(3) (-\sqrt{3}, -3) = (2\sqrt{3} \cos 240^\circ, 2\sqrt{3} \sin 240^\circ) = (2\sqrt{3} \cos(-120)^\circ, 2\sqrt{3} \sin(-120)^\circ)$$

$$(4) (3, -3) = (3\sqrt{2} \cos(-45^\circ), 3\sqrt{2} \sin(-45^\circ)) = (3\sqrt{2} \cos 315^\circ, 3\sqrt{2} \sin 315^\circ)$$

< 40 ページ. 加法定理 1 >

問の解答

(1) $P(\cos \beta, \sin \beta)$

(2) $Q(\cos \alpha, -\sin \alpha)$

(3) $PQ^2 = (\cos \beta - \cos \alpha)^2 + (\sin \beta + \sin \alpha)^2$

(4)
$$\begin{aligned} PQ^2 &= \cos^2 \beta - 2 \cos \beta \cos \alpha + \cos^2 \alpha + \sin^2 \beta + 2 \sin \beta \sin \alpha + \sin^2 \alpha \\ &= 2 - 2 \cos \alpha \cos \beta + 2 \sin \alpha \sin \beta \end{aligned}$$

(5)
$$\begin{aligned} PQ^2 &= 1^2 + 1^2 - 2 \times 1 \times 1 \times \cos(\alpha + \beta) \\ &= 2 - 2 \cos(\alpha + \beta) \end{aligned}$$

(6) $\cos(\alpha + \beta) = \cos \alpha \cos \beta - \sin \alpha \sin \beta$

< 41 ページ. 加法定理 2 >

問の解答

$$\begin{aligned}\sin(\alpha + \beta) &= \cos(90^\circ - \alpha - \beta) \\ &= \cos\{(90^\circ - \alpha) + (-\beta)\} \\ &= \cos(90^\circ - \alpha) \cos(-\beta) - \sin(90^\circ - \alpha) \sin(-\beta) \\ &= \sin \alpha \cos \beta + \cos \alpha \sin \beta\end{aligned}$$

< 42 ページ. 加法定理 3 >

問 1 の解答

$$(1) \cos 105^\circ = \cos(60^\circ + 45^\circ) = \cos 60^\circ \cos 45^\circ - \sin 60^\circ \sin 45^\circ$$

$$\begin{aligned} &= \frac{1}{2} \times \frac{\sqrt{2}}{2} - \frac{\sqrt{3}}{2} \times \frac{\sqrt{2}}{2} \\ &= \frac{\sqrt{2} - \sqrt{6}}{4} \end{aligned}$$

$$(2) \sin 105^\circ = \sin(60^\circ + 45^\circ) = \sin 60^\circ \cos 45^\circ + \cos 60^\circ \sin 45^\circ$$

$$\begin{aligned} &= \frac{\sqrt{3}}{2} \times \frac{\sqrt{2}}{2} + \frac{1}{2} \times \frac{\sqrt{2}}{2} \\ &= \frac{\sqrt{6} + \sqrt{2}}{4} \end{aligned}$$

問 2 の解答

$$\begin{aligned} (1) \cos(\alpha - \beta) &= \cos(\alpha + (-\beta)) = \cos \alpha \cos(-\beta) - \sin \alpha \sin(-\beta) \\ &= \cos \alpha \cos \beta + \sin \alpha \sin \beta \end{aligned}$$

$$\begin{aligned} (2) \sin(\alpha - \beta) &= \sin(\alpha + (-\beta)) = \sin \alpha \cos(-\beta) + \cos \alpha \sin(-\beta) \\ &= \sin \alpha \cos \beta - \cos \alpha \sin \beta \end{aligned}$$

問 3 の解答

$$(1) \cos(-15^\circ) = \cos(30^\circ - 45^\circ) = \cos 30^\circ \cos 45^\circ + \sin 30^\circ \sin 45^\circ$$

$$\begin{aligned} &= \frac{\sqrt{3}}{2} \times \frac{\sqrt{2}}{2} + \frac{1}{2} \times \frac{\sqrt{2}}{2} \\ &= \frac{\sqrt{6} + \sqrt{2}}{4} \end{aligned}$$

$$(2) \sin(-15^\circ) = \sin(30^\circ - 45^\circ) = \sin 30^\circ \cos 45^\circ - \cos 30^\circ \sin 45^\circ$$

$$\begin{aligned} &= \frac{1}{2} \times \frac{\sqrt{2}}{2} - \frac{\sqrt{3}}{2} \times \frac{\sqrt{2}}{2} \\ &= \frac{\sqrt{2} - \sqrt{6}}{4} \end{aligned}$$

< 43 ページ. 加法定理 4 >

問 1 の解答

$$\begin{aligned}
 (1) \tan 105^\circ &= \frac{\sin 105^\circ}{\cos 105^\circ} = \frac{\sin 60^\circ \cos 45^\circ + \cos 60^\circ \sin 45^\circ}{\cos 60^\circ \cos 45^\circ - \sin 60^\circ \sin 45^\circ} \\
 &= \frac{\frac{\sqrt{3}}{2} \times \frac{\sqrt{2}}{2} + \frac{1}{2} \times \frac{\sqrt{2}}{2}}{\frac{1}{2} \times \frac{\sqrt{2}}{2} - \frac{\sqrt{3}}{2} \times \frac{\sqrt{2}}{2}} \\
 &= \frac{\sqrt{6} + \sqrt{2}}{\sqrt{2} - \sqrt{6}} = \frac{(\sqrt{6} + \sqrt{2})^2}{2 - 6} = \frac{6 + 2\sqrt{12} + 2}{-4} \\
 &= -2 - \sqrt{3}
 \end{aligned}$$

問 2 の解答

$$\begin{aligned}
 \tan(\alpha + \beta) &= \frac{\sin \alpha \cos \beta + \cos \alpha \sin \beta}{\cos \alpha \cos \beta - \sin \alpha \sin \beta} \\
 &= \frac{\frac{\sin \alpha}{\cos \alpha} + \frac{\sin \beta}{\cos \beta}}{1 - \frac{\sin \alpha \sin \beta}{\cos \alpha \cos \beta}} \\
 &= \frac{\tan \alpha + \tan \beta}{1 - \tan \alpha \tan \beta}
 \end{aligned}$$

問 3 の解答

$$\tan(\alpha - \beta) = \frac{\tan \alpha + \tan(-\beta)}{1 - \tan \alpha \tan(-\beta)} = \frac{\tan \alpha - \tan \beta}{1 + \tan \alpha \tan \beta}$$

< 44 ページ. 加法定理の応用 1 >

問 1 の解答

$$(1) \cos(\theta + 360^\circ) = \cos \theta \cos 360^\circ - \sin \theta \sin 360^\circ = (\cos \theta) \times 1 - (\sin \theta) \times 0 = \cos \theta$$

$$(2) \tan(\theta + 360^\circ) = \frac{\tan \theta + \tan 360^\circ}{1 - \tan \theta \tan 360^\circ} = \frac{\tan \theta + 0}{1 - (\tan \theta) \times 0} = \frac{\tan \theta}{1} = \tan \theta$$

$$(3) \cos(-\theta) = \cos(360^\circ - \theta) = \cos 360^\circ \cos \theta + \sin 360^\circ \sin \theta = 1 \times \cos \theta + 0 \times \sin \theta = \cos \theta$$

$$(4) \tan(-\theta) = \tan(360^\circ - \theta) = \frac{\tan 360^\circ - \tan \theta}{1 + \tan 360^\circ \tan \theta} = \frac{0 - \tan \theta}{1 + 0 \times \tan \theta} = -\tan \theta$$

$$(5) \sin(\theta + 180^\circ) = \sin \theta \cos 180^\circ + \cos \theta \sin 180^\circ = (\sin \theta) \times (-1) + (\cos \theta) \times 0 = -\sin \theta$$

$$(6) \cos(\theta + 180^\circ) = \cos \theta \cos 180^\circ - \sin \theta \sin 180^\circ = (\cos \theta) \times (-1) - (\sin \theta) \times 0 = -\cos \theta$$

$$(7) \sin(180^\circ - \theta) = \sin 180^\circ \cos \theta - \cos 180^\circ \sin \theta = 0 \times \cos \theta - (-1) \times \sin \theta = \sin \theta$$

$$(8) \cos(180^\circ - \theta) = \cos 180^\circ \cos \theta + \sin 180^\circ \sin \theta = -1 \times \cos \theta + 0 \times \sin \theta = -\cos \theta$$

$$(9) \tan(180^\circ - \theta) = \frac{\tan 180^\circ - \tan \theta}{1 + \tan 180^\circ \tan \theta} = \frac{0 - \tan \theta}{1 + 0 \times \tan \theta} = -\tan \theta$$

$$(10) \sin(\theta + 90^\circ) = \sin \theta \cos 90^\circ + \cos \theta \sin 90^\circ = (\sin \theta) \times 0 + (\cos \theta) \times 1 = \cos \theta$$

$$(11) \cos(\theta + 90^\circ) = \cos \theta \cos 90^\circ - \sin \theta \sin 90^\circ = (\cos \theta) \times 0 - (\sin \theta) \times 1 = -\sin \theta$$

$$(12) \sin(90^\circ - \theta) = \sin 90^\circ \cos \theta - \cos 90^\circ \sin \theta = 1 \times \cos \theta - 0 \times \sin \theta = \cos \theta$$

$$(13) \cos(90^\circ - \theta) = \cos 90^\circ \cos \theta + \sin 90^\circ \sin \theta = 0 \times \cos \theta + 1 \times \sin \theta = \sin \theta$$

問 2 の解答

$$(1) \sin(2\alpha) = 2 \sin \alpha \cos \alpha$$

$$(2) \cos(2\alpha) = \cos^2 \alpha - \sin^2 \alpha \quad \left(= 2 \cos^2 \alpha - 1 = 1 - 2 \sin^2 \alpha \right)$$

$$(3) \tan(2\alpha) = \frac{2 \tan \alpha}{1 - \tan^2 \alpha}$$

< 45 ページ. 加法定理の応用 2 >

問の解答

$$\begin{aligned}(1) \quad \sin \theta + \sqrt{3} \cos \theta &= 2 \left(\frac{1}{2} \sin \theta + \frac{\sqrt{3}}{2} \cos \theta \right) \\ &= 2(\cos 60^\circ \sin \theta + \sin 60^\circ \cos \theta) \\ &= 2 \sin(\theta + 60^\circ)\end{aligned}$$

$$\begin{aligned}(2) \quad -\sin \theta + \cos \theta &= \sqrt{2} \left(-\frac{1}{\sqrt{2}} \sin \theta + \frac{1}{\sqrt{2}} \cos \theta \right) \\ &= \sqrt{2}(\cos 135^\circ \sin \theta + \sin 135^\circ \cos \theta) \\ &= \sqrt{2} \sin(\theta + 135^\circ)\end{aligned}$$

$$\begin{aligned}(3) \quad -\sqrt{3} \sin \theta - \cos \theta &= 2 \left(-\frac{\sqrt{3}}{2} \sin \theta - \frac{1}{2} \cos \theta \right) \\ &= 2(\cos 210^\circ \sin \theta + \sin 210^\circ \cos \theta) \\ &= 2 \sin(\theta + 210^\circ) \\ &= 2 \sin(\theta - 150^\circ)\end{aligned}$$

$$\begin{aligned}(4) \quad \sin \theta - \cos \theta &= \sqrt{2} \left(\frac{1}{\sqrt{2}} \sin \theta - \frac{1}{\sqrt{2}} \cos \theta \right) \\ &= \sqrt{2}(\cos 315^\circ \sin \theta + \sin 315^\circ \cos \theta) \\ &= \sqrt{2} \sin(\theta + 315^\circ) \\ &= \sqrt{2} \sin(\theta - 45^\circ)\end{aligned}$$

< 46 ページ. 三角関数のグラフ 1 >

問の解答

(1) $y = \sin \theta$ ($-180^\circ \leq \theta \leq 540^\circ$)

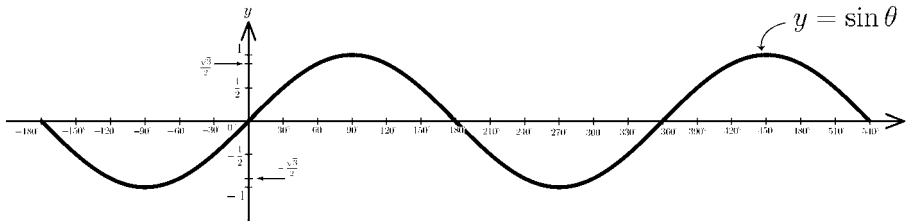

(2) $y = \cos \theta$ ($-180^\circ \leq \theta \leq 540^\circ$)

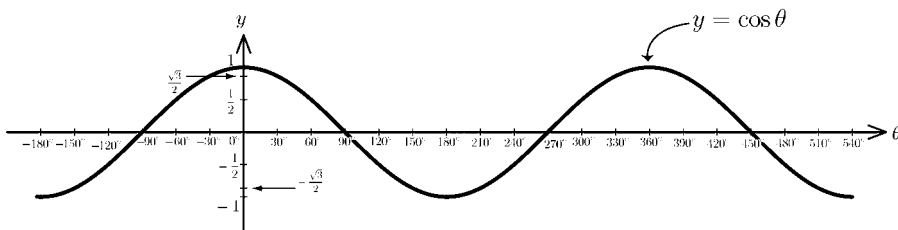

(3) $y = \tan \theta$ ($-90^\circ \leq \theta \leq 450^\circ$)

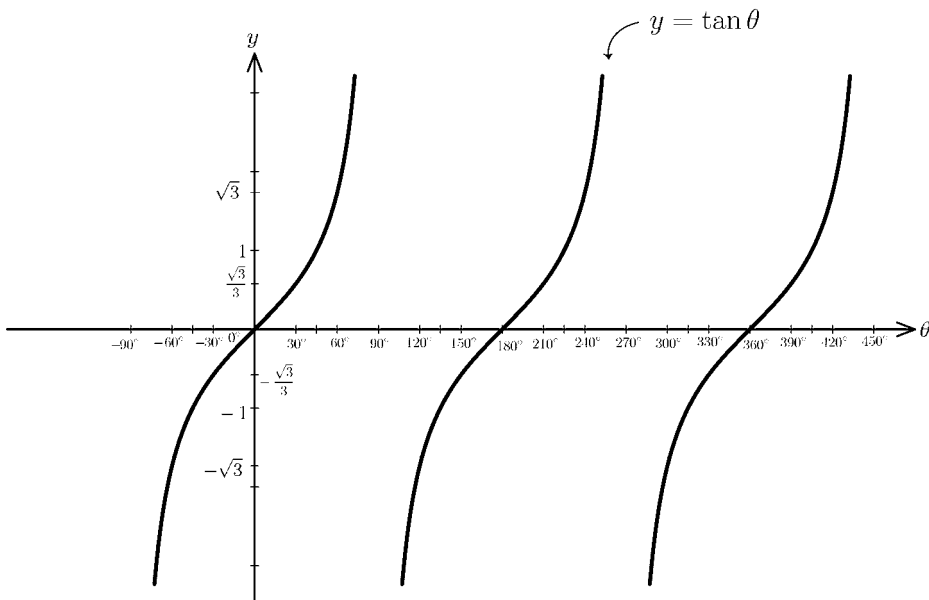

< 47 ページ. 三角関数のグラフ 2 >

問 1 の解答

$\cos \theta$ の周期は 360° , $\tan \theta$ の周期は 180°

問 2 の解答

(1) $y = \sin(\theta - 90^\circ)$

周期 360°

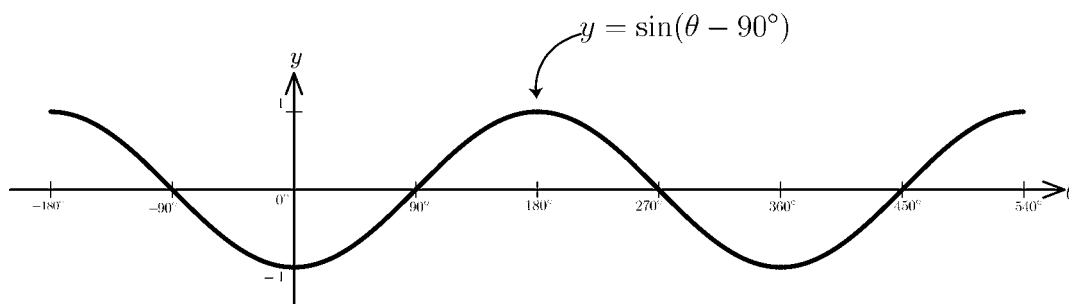

(2) $y = -\frac{1}{2} \cos \theta$

周期 360°

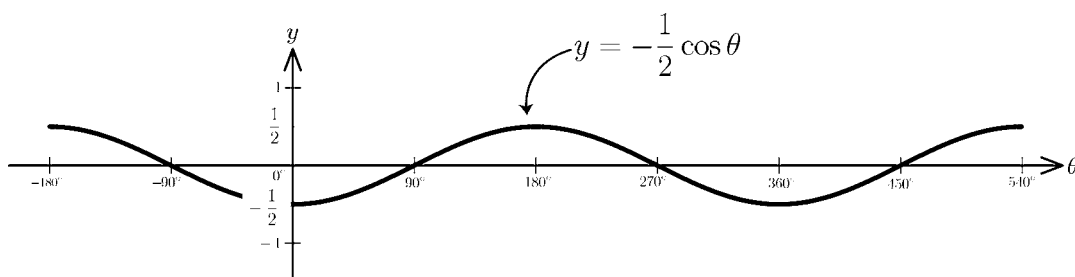

< 48 ページ. 三角関数のグラフ 3 >

問の解答

(1) $y = \sin(3\theta)$

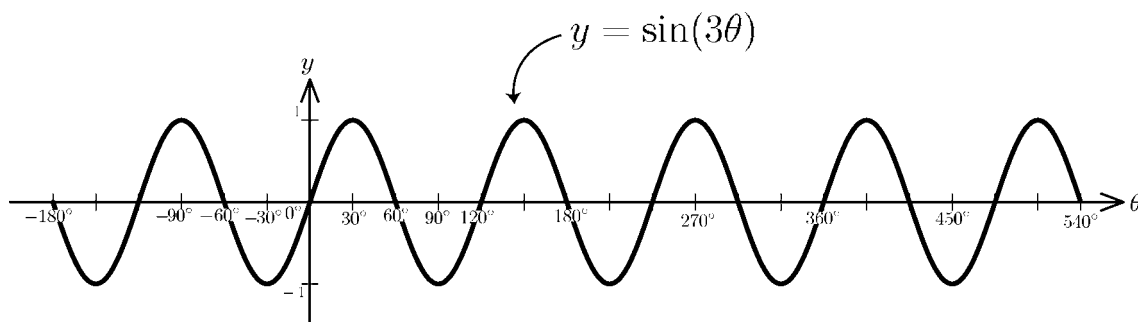
周期 120° 

(2) $y = \sqrt{2} \sin(\theta - 45^\circ)$

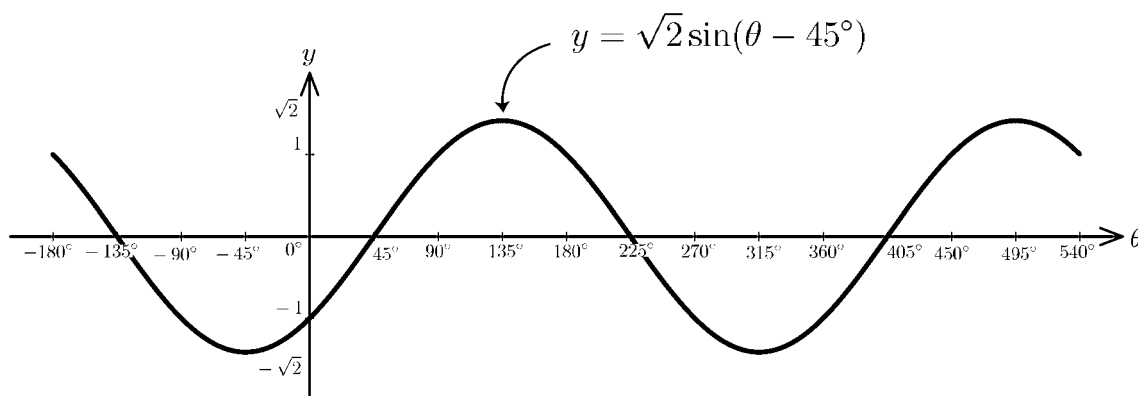
周期 360° 

< 49 ページ. 三角関数のグラフ 4 >

問の解答

(1) $y = -\sin \theta + \cos \theta = \sqrt{2} \sin(\theta + 135^\circ)$

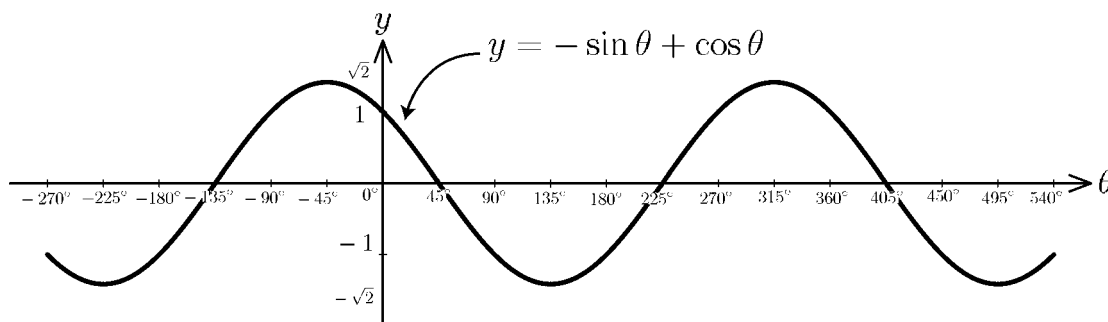
 y の最大値は $\sqrt{2}$, y の最小値は $-\sqrt{2}$ 

(2) $y = \sin \theta - \sqrt{3} \cos \theta = 2 \sin(\theta - 60^\circ)$

 y の最大値は 2 , y の最小値は -2