

高知工科大学

基礎数学ワークブック

(2004年度版)

入門編

*No. 3*

解答

## &lt; 1 ページ. 関数の値 &gt;

## 問 1 の解答

- (1)  $f(0) = 5$  ,  $f(1) = 3$  ,  $f(2) = 3$   
(2)  $f(1) = -1$  ,  $f(2) = 4$  ,  $f(3) = 21$   
(3)  $f(-3) = 108$  ,  $f(0) = 0$  ,  $f(3) = 54$   
(4)  $f(0) = -1$  ,  $f(1) = 0$  ,  $f(5) = 144$

## 問 2 の解答

- (1)  $f(a) = a^3$  ,  $f(a+h) = (a+h)^3$   
(2)  $f(a) = a+1$  ,  $f(a+h) = a+h+1$   
(3)  $f(a) = 2a^2 - 5$  ,  $f(a+h) = 2(a+h)^2 - 5$   
(4)  $f(a) = a^2 + 3a$  ,  $f(a+h) = (a+h)^2 + 3(a+h)$

## &lt; 2 ページ. 接線 &gt;

## 問の解答

$$(1) \frac{(1+h)^2 - 1}{h} = \frac{1 + 2h + h^2 - 1}{h} = 2 + h$$

$$(2) 2 + h = 2 + 0.1 = 2.1$$

$$(3) 2 + h = 2 + 0.01 = 2.01$$

## &lt; 3 ページ. 極限 1 &gt;

## 問 1 の解答

接線の傾き

## 問 2 の解答

$$\begin{aligned} (1) \quad \lim_{h \rightarrow 0} \frac{(4+h)^2 - 16}{h} &= \lim_{h \rightarrow 0} \frac{16 + 8h + h^2 - 16}{h} \\ &= \lim_{h \rightarrow 0} (8 + h) \\ &= 8 \end{aligned}$$

$$\begin{aligned} (2) \quad \lim_{h \rightarrow 0} \frac{(\frac{1}{2} + h)^2 - \frac{1}{4}}{h} &= \lim_{h \rightarrow 0} \frac{\frac{1}{4} + h + h^2 - \frac{1}{4}}{h} \\ &= \lim_{h \rightarrow 0} (1 + h) \\ &= 1 \end{aligned}$$

## &lt; 4 ページ. 極限 2 &gt;

## 問 1 の解答

$$(1) \lim_{h \rightarrow 0} \frac{5(1+h)^2 - 5}{h} = \lim_{h \rightarrow 0} \frac{5 + 10h + 5h^2 - 5}{h} = 10$$

$$(2) \lim_{h \rightarrow 0} \frac{3(2+h)^2 - 12}{h} = \lim_{h \rightarrow 0} \frac{12 + 12h + 3h^2 - 12}{h} = 12$$

$$(3) \lim_{h \rightarrow 0} \frac{(1+h)^3 - 1}{h} = \lim_{h \rightarrow 0} \frac{1 + 3h + 3h^2 + h^3 - 1}{h} = 3$$

$$(4) \lim_{h \rightarrow 0} \frac{(3+h)^2 - 27}{h} = \lim_{h \rightarrow 0} \frac{27 + 27h + 9h^2 + h^3 - 27}{h} = 27$$

## 問 2 の解答

$$(1) \lim_{h \rightarrow 0} \frac{3(a+h) - 3a}{h} = 3$$

$$(2) \lim_{h \rightarrow 0} \frac{(a+h)^2 - a^2}{h} = \lim_{h \rightarrow 0} \frac{a^2 + 2ah + h^2 - a^2}{h} = 2a$$

$$(3) \lim_{h \rightarrow 0} \frac{(a+h)^3 - a^3}{h} = \lim_{h \rightarrow 0} \frac{a^3 + 3a^2h + 3ah^2 + h^3 - a^3}{h} = 3a^2$$

< 5 ページ. 接線の傾き 1 >

問 1 の解答

$$\lim_{h \rightarrow 0} \frac{\left(\frac{1}{2} + h\right)^2 - \frac{1}{4}}{h} = \lim_{h \rightarrow 0} \frac{\frac{1}{4} + h + h^2 - \frac{1}{4}}{h} = \lim_{h \rightarrow 0} (1 + h) = 1$$

問 2 の解答

$$\lim_{h \rightarrow 0} \frac{(2 + h)^2 - 4}{h} = \lim_{h \rightarrow 0} \frac{4 + 4h + h^2 - 4}{h} = 4$$

問 3 の解答

$$\lim_{h \rightarrow 0} \frac{\left(\frac{3}{2} + h\right)^2 - \frac{9}{4}}{h} = \lim_{h \rightarrow 0} \frac{\frac{9}{4} + 3h + h^2 - \frac{9}{4}}{h} = 3$$

< 6 ページ. 接線の傾き 2 >

問 1 の解答

(1)

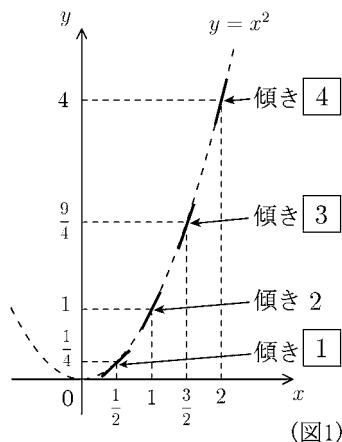

(2)  $x = 2$  のときの傾き  $= \lim_{h \rightarrow 0} \frac{(2+h)^2 - 2^2}{h} = \boxed{4}$

$x = \frac{3}{2}$  のときの傾き  $= \lim_{h \rightarrow 0} \frac{\left(\frac{3}{2} + h\right)^2 - \left(\frac{3}{2}\right)^2}{h} = \boxed{3}$

$x = \frac{1}{2}$  のときの傾き  $= \lim_{h \rightarrow 0} \frac{\left(\frac{1}{2} + h\right)^2 - \left(\frac{1}{2}\right)^2}{h} = \boxed{1}$

$x = 0$  のときの傾き  $= \lim_{h \rightarrow 0} \frac{\left(0 + h\right)^2 - \left(0\right)^2}{h} = \boxed{0}$

(3)

$x$	0	$\frac{1}{2}$	1	$\frac{3}{2}$	2
傾き	0	1	2	3	4

傾き =  $2x$

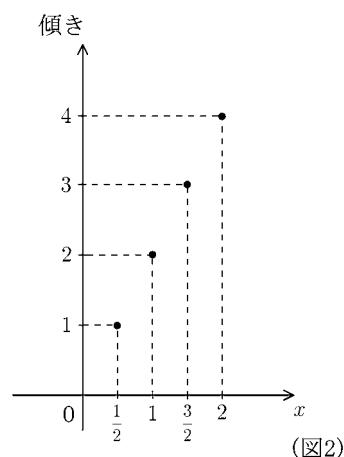

問 2 の解答

$x = a$  のときの傾き  $= \lim_{h \rightarrow 0} \frac{(a+h)^2 - a^2}{h} = 2a$

問 3 の解答

(1)  $x = -1$  のときの傾き  $= 2 \times (-1) = -2$

(2)  $x = -2$  のときの傾き  $= 2 \times (-2) = -4$

## &lt; 7ページ. 接線の傾き 3 &gt;

## 問 1 の解答

$$\text{接線の傾き} = \lim_{h \rightarrow 0} \frac{(1+h)^3 - 1^3}{h} = 3$$

## 問 2 の解答

$$\begin{aligned} \text{接線の傾き} &= \lim_{h \rightarrow 0} \frac{(a+h)^3 - a^3}{h} \\ &= \lim_{h \rightarrow 0} \frac{a^3 + 3a^2h + 3ah^2 + h^3 - a^3}{h} \\ &= \lim_{h \rightarrow 0} (3a^2 + 3ah + h^2) \\ &= 3a^2 \end{aligned}$$

## 問 3 の解答

- (1)  $x = \frac{1}{2}$  のときの傾き  $= 3 \times \left(\frac{1}{2}\right)^2 = \frac{3}{4}$
- (2)  $x = 0$  のときの傾き  $= 3 \times 0^2 = 0$
- (3)  $x = -\frac{1}{2}$  のときの傾き  $= 3 \times \left(-\frac{1}{2}\right)^2 = \frac{3}{4}$
- (4)  $x = -1$  のときの傾き  $= 3 \times (-1)^2 = 3$

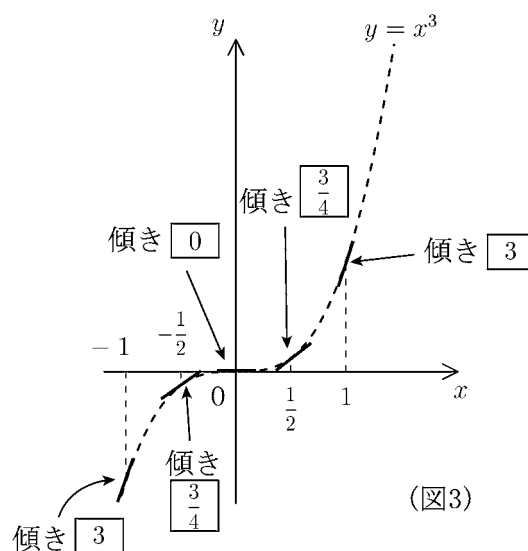

## &lt; 8 ページ. 微分係数 1 &gt;

## 問 1 の解答

$$\text{接線の傾き} = \lim_{h \rightarrow 0} \frac{f(a+h) - f(a)}{h}$$

## 問 2 の解答

$f'(a)$  は曲線  $y = f(x)$  上の点  $(a, f(a))$  における接線の傾き

## 問 3 の解答

$$(1) f(x) = x^4 \text{ のとき } f'(a) = \lim_{h \rightarrow 0} \frac{(a+h)^4 - a^4}{h}$$

$$(2) f(x) = 4x^3 \text{ のとき } f'(a) = \lim_{h \rightarrow 0} \frac{4(a+h)^3 - 4a^3}{h}$$

$$(3) f(x) = x^2 - 4x \text{ のとき } f'(a) = \lim_{h \rightarrow 0} \frac{(a+h)^2 - 4(a+h) - a^2 + 4a}{h}$$

$$(4) f(x) = x^3 + 3x^2 \text{ のとき } f'(a) = \lim_{h \rightarrow 0} \frac{(a+h)^3 + 3(a+h)^2 - a^3 - 3a^2}{h}$$

## &lt; 9 ページ. 微分係数 2 &gt;

## 問の解答

$$(1) f'(a) = \lim_{h \rightarrow 0} \frac{3(a+h)^2 - 3a^2}{h}$$

$$= \lim_{h \rightarrow 0} \frac{3a^2 + 6ah + 3h^2 - 3a^2}{h}$$

$$= 6a$$

$$(2) f'(a) = \lim_{h \rightarrow 0} \frac{(a+h)^2 + 3(a+h)^2 - a^3 - 3a^2}{h}$$

$$= \lim_{h \rightarrow 0} (2a + h - 4)$$

$$= 2a - 4$$

$$(3) f'(a) = \lim_{h \rightarrow 0} \frac{(a+h)^3 + 3(a+h)^2 - a^3 - 3a^2}{h}$$

$$= \lim_{h \rightarrow 0} \frac{a^3 + 3a^2h + 3ah^2 + h^3 + 3a^2 + 6ah + 3h^2 - a^3 - 3a^2}{h}$$

$$= \lim_{h \rightarrow 0} (3a^2 + 3ah + h^2 + 6a + 3h)$$

$$= 3a^2 + 6a$$

## &lt; 10 ページ. 微分係数 3 &gt;

## 問 1 の解答

$$f'(a) = 2a - 4$$

$$f'(0) = -4$$

$$f'(1) = -2$$

$$f'(2) = 0$$

$$f'(3) = 2$$

$$f'(4) = 4$$

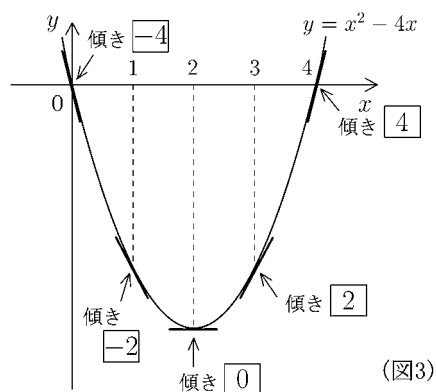

## 問 2 の解答

$$f'(a) = 3a^2 + 6a$$

$$f'(-3) = 9$$

$$f'(-2) = 0$$

$$f'(-1) = -3$$

$$f'(0) = 0$$

$$f'(1) = 9$$

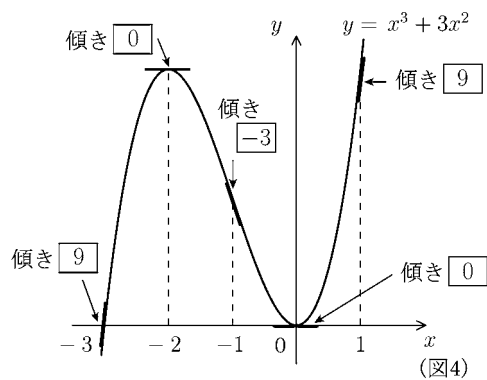

## &lt; 11 ページ. 導関数 1 &gt;

## 問 1 の解答

(1)  $f'(-\frac{1}{2}) = -3$

(2)  $f'(\frac{1}{2}) = -1$

(3)  $f'(\frac{3}{2}) = 1$

(4)  $f'(\frac{5}{2}) = 3$

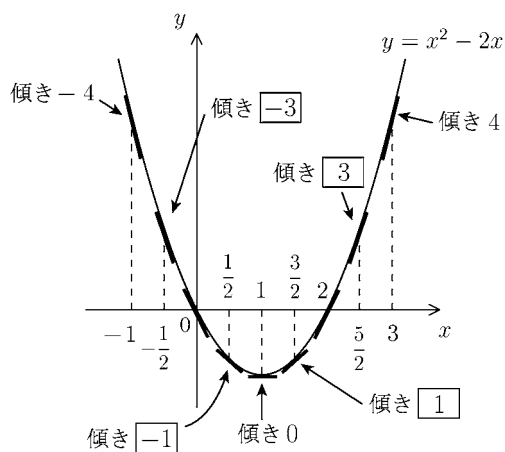

## 問 2 の解答

(1)  $f(x) = x^2$

$f'(a) = 2a$

$f'(x) = 2x$

(2)  $f(x) = x^3$

$f'(a) = 3a^2$

$f'(x) = 3x^2$

(3)  $f(x) = 5x^2$

$f'(a) = 10a$

$f'(x) = 10x$

(4)  $f(x) = 2x^2 - 4x$

$f'(a) = 2a - 4$

$f'(x) = 2x - 4$

(5)  $f(x) = x^3 + x^2$

$f'(a) = 3a^2 + 2a$

$f'(x) = 3x^2 + 2x$

(6)  $f(x) = x^3 + 3x^2$

$f'(a) = 3a^2 + 6a$

$f'(x) = 3x^2 + 6x$

## &lt; 12 ページ. 導関数 2 &gt;

## 問 1 の解答

(1)  $f'(x) = 0$

(2)  $f'(x) = 5$

## 問 2 の解答

(1)  $(3)' = 0$

(2)  $(2)' = 0$

(3)  $(2x - 1)' = 2$

(4)  $(5x - 2)' = 5$

(5)  $(5x^2)' = 10x$

(6)  $(x^2 - 2x)' = 2x - 2$

(7)  $(x^2 - 4x)' = 2x - 4$

(8)  $(x^3 + x^2)' = 3x^2 + 2x$

(9)  $(x^3 + 3x^2)' = 3x^2 + 6x$

## &lt; 13 ページ. 導関数 3 &gt;

## 問の解答

(1)  $(x^3 + 2)' = 3x^2$

(2)  $(3x^2 - 2x^3)' = 6x - 6x^2$

(3)  $(x^2 - 3x + 2)' = 2x - 3$

(4)  $(3x^3 - x^2 + 5x - 1)' = 9x^2 - 2x + 5$

< 14 ページ. パスカルの三角形 >

問 1 の解答

$$(1) (a+b)^4 = (a+b)(a+b)^3 = (a+b)(a^3 + 3a^2b + 3ab^2 + b^3)$$

$$= \boxed{1} \times a^4 + \boxed{4} \times a^3b + \boxed{6} \times a^2b^2 + \boxed{4} \times ab^3 + \boxed{1} \times b^4$$

$$(2) (a+b)^5 = (a+b) \left( \boxed{1} \times a^4 + \boxed{4} \times a^3b + \boxed{6} \times a^2b^2 + \boxed{4} \times ab^3 + \boxed{1} \times b^4 \right)$$

$$= \boxed{1} \times a^5 + \boxed{5} \times a^4b + \boxed{10} \times a^3b^2 + \boxed{10} \times a^2b^3 + \boxed{5} \times ab^4 + \boxed{1} \times b^5$$

問 2 の解答

$$(a+b)^0 = 1 \dots\dots\dots 1$$

$$(a+b)^1 = 1 \times a + 1 \times b^2 \dots\dots\dots 1 \quad 1$$

$$(a+b)^2 = 1 \times a^2 + 2 \times ab + 1 \times b^2 \dots\dots\dots 1 \quad 2 \quad 1$$

$$(a+b)^3 = 1 \times a^3 + 3 \times a^2b + 3 \times ab^2 + 1 \times b^3 \dots\dots\dots 1 \quad 3 \quad 3 \quad 1$$

$$(a+b)^4 = \boxed{1} \times a^4 + \boxed{4} \times a^3b + \boxed{6} \times a^2b^2 + \boxed{4} \times ab^3 + \boxed{1} \times b^4 \dots\dots\dots \boxed{1} \quad \boxed{4} \quad \boxed{6} \quad \boxed{4} \quad \boxed{1}$$

$$(a+b)^5 = \boxed{1} \times a^5 + \boxed{5} \times a^4b + \boxed{10} \times a^3b^2 + \boxed{10} \times a^2b^3 + \boxed{5} \times ab^4 + \boxed{1} \times b^5 \quad \boxed{1} \quad \boxed{5} \quad \boxed{10} \quad \boxed{10} \quad \boxed{5} \quad \boxed{1}$$

$$(a+b)^6 = \boxed{1} \times a^6 + \boxed{6} \times a^5b + \boxed{15} \times a^4b^2 + \boxed{20} \times a^3b^3 + \boxed{15} \times a^2b^4 + \boxed{6} \times ab^5 + \boxed{1} \times b^6$$

問 3 の解答

$$(1) (x+h)^4 = x^4 + 4x^3h + 6x^2h^2 + 4xh^3 + h^4$$

$$(2) (x+h)^5 = x^5 + 5x^4h + 10x^3h^2 + 10x^2h^3 + 5xh^4 + h^5$$

$$(3) (x+h)^6 = x^6 + 6x^5h + 15x^4h^2 + 20x^3h^3 + 15x^2h^4 + 6xh^5 + h^6$$

## &lt; 15 ページ. 整関数の微分 1 &gt;

## 問の解答

$$\begin{aligned}(x^4)' = f'(x) &= \lim_{h \rightarrow 0} \frac{f(x+h) - f(x)}{h} \\ &= \lim_{h \rightarrow 0} \frac{(x+h)^4 - x^4}{h} \\ &= \lim_{h \rightarrow 0} \frac{x^4 + 4x^3h + 6x^2h^2 + 4xh^3 + h^4 - x^4}{h} \\ &= \lim_{h \rightarrow 0} (4x^3 + 6x^2h + 4xh^2 + h^3) \\ &= 4x^3\end{aligned}$$

## &lt; 16 ページ. 整関数の微分 2 &gt;

## 問 1 の解答

$$\begin{aligned}
 (x^5)' = f'(x) &= \lim_{h \rightarrow 0} \frac{f(x+h) - f(x)}{h} \\
 &= \lim_{h \rightarrow 0} \frac{(x+h)^5 - x^5}{h} \\
 &= \lim_{h \rightarrow 0} \frac{x^5 + 5x^4h + 10x^3h^2 + 10x^2h^3 + 5xh^4 + h^5 - x^5}{h} \\
 &= \lim_{h \rightarrow 0} (5x^4 + 10x^3h + 10x^2h^2 + 5xh^3 + h^4) \\
 &= 5x^4
 \end{aligned}$$

## 問 2 の解答

$$\begin{aligned}
 (x^6)' = f'(x) &= \lim_{h \rightarrow 0} \frac{f(x+h) - f(x)}{h} \\
 &= \lim_{h \rightarrow 0} \frac{(x+h)^6 - x^6}{h} \\
 &= \lim_{h \rightarrow 0} \frac{x^6 + 6x^5h + 15x^4h^2 + 20x^3h^3 + 15x^2h^4 + 6xh^5 + h^6 - x^6}{h} \\
 &= \lim_{h \rightarrow 0} (6x^5 + 15x^4h + 20x^3h^2 + 15x^2h^3 + 6xh^4 + h^5) \\
 &= 6x^5
 \end{aligned}$$

## 問 3 の解答

元の関数 $f(x)$	$x^0$	$x^1$	$x^2$	$x^3$	$x^4$	$x^5$	$x^6$
導関数 $f'(x)$	0	1	$2x$	$3x^2$	$4x^3$	$5x^4$	$6x^5$

## 問 4 の解答

$$(x^n)' = n x^{n-1}$$

## &lt; 17 ページ. 整関数の微分 3 &gt;

## 問の解答

(1)  $(x - x^3)' = 1 - 3x^2$

(2)  $(7x^6)' = 42x^5$

(3)  $(10x^4 + 8x^7)' = 40x^3 + 56x^6$

(4)  $(6x^5 - 2x^3 + 3)' = 30x^4 - 6x^2$

(5)  $(3x^5 - 6x^2 + 9)' = 15x^4 - 12x$

(6)  $(4x^7 - 4x^4 + 9x^2 - 5x)' = 28x^6 - 16x^3 + 18x - 5$

(7)  $((x - 1)(x + 4))' = (x^2 + 3x - 4)' = 2x + 3$

(8)  $((x^2 - 3)(x^2 - 2))' = (x^4 - 5x^2 + 6)' = 4x^3 - 10x$

## &lt; 18 ページ. 微分の練習 &gt;

## 問 1 の解答

$$(1) \lim_{h \rightarrow 0} \frac{3(1+h)^2 - 3}{h} = \lim_{h \rightarrow 0} \frac{3 + 6h + 3h^2 - 3}{h} = 6$$

$$(2) \lim_{h \rightarrow 0} \frac{(a+h)^3 - a^3}{h} = \lim_{h \rightarrow 0} \frac{a^3 + 3a^2h + 3ah^2 + h^3 - a^3}{h} = 3a^2$$

$$(3) \lim_{h \rightarrow 0} \frac{(a+h)^2 + 3(a+h) - a^2 - 3a}{h} = \lim_{h \rightarrow 0} \frac{a^2 + 2ah + h^2 + 3a + 3h - a^2 - 3a}{h} \\ = \lim_{h \rightarrow 0} (2a + h + 3) = 2a + 3$$

## 問 2 の解答

$$(1) y = 2(x+1)(x-4) = 2x^2 - 6x - 8 \quad \underline{\text{(答) } y' = 4x - 6}$$

$$(2) y = (x-1)^3 = x^3 - 3x^2 + 3x - 1 \quad \underline{\text{(答) } y' = 3x^2 - 6x + 3}$$

## 問 3 の解答

$$(1) y' = 2x - 2, \quad x = -1 \text{ のとき } y' = 2 \times (-1) - 2 = -4 \quad \underline{\text{(答) } -4}$$

$$(2) y' = 3x^2, \quad x = 2 \text{ のとき } y' = 3 \times 2^2 = 12 \quad \underline{\text{(答) } 12}$$

$$(3) y' = 3x^2 + 2x, \quad x = 1 \text{ のとき } y' = 3 + 2 = 5 \quad \underline{\text{(答) } 5}$$

## 問 4 の解答

$$(1) y' = 3x^2 - 2x, \quad x = 3 \text{ のとき } y' = 3 \times 3^2 - 2 \times 3 = 21 \quad \underline{\text{(答) } 21}$$

$$(2) y' = 3x^2 - 2x, \quad x = a \text{ のとき} \\ \Rightarrow y' = 3a^2 - 2a = 1 \Rightarrow 3a^2 - 2a - 1 = 0 \Rightarrow (3a+1)(a-1) = 0 \\ \Rightarrow a = -\frac{1}{3}, 1 \\ b = a^3 - a^2 = -\frac{4}{27}, 0 \quad \underline{\text{(答) } (a, b) = \left(-\frac{1}{3}, -\frac{4}{27}\right) \text{ または } (1, 0)}$$

## 問 5 の解答

$$f(1) = 1 + a + b + c = 3 \Rightarrow a + b + c = 2 \dots\dots \textcircled{1}$$

$$f'(x) = 3x^2 + 2ax + b$$

$$f'(1) = 3 + 2a + b = 10 \Rightarrow 2a + b = 7 \dots\dots \textcircled{2}$$

$$f'(2) = 12 + 4a + b = 25 \Rightarrow 4a + b = 13 \dots\dots \textcircled{3}$$

①, ②, ③より

$$a = 3, \quad b = 1, \quad c = -2 \quad \underline{\text{(答) } f(x) = x^3 + 3x^2 + x - 2}$$

## &lt; 19 ページ. 関数の増減 1 &gt;

## 問の解答

(1)  $y' = 2x - 2$  , 頂点 (1, 2)

$x$	$x < 1$	1	$1 < x$
$y'$	-	0	+
$y$	↘	2	↗

(2)  $y' = -4x + 8$  , 頂点 (2, 7)

$x$	$x < 2$	2	$2 < x$
$y'$	+	0	-
$y$	↗	7	↘

## &lt; 20 ページ. 関数の増減 2 &gt;

## 問の解答

$$\begin{aligned}
 y' &= 12 - 3x^2 \\
 &= 3(4 - x^2) \\
 &= -3(x - 2)(x + 2)
 \end{aligned}$$

$x$	$x < -2$	$-2$	$-2 < x < 2$	$2$	$2 < x$
$y'$	$-$	$0$	$+$	$0$	$-$
$y$	$\searrow$	$-16$	$\nearrow$	$16$	$\searrow$

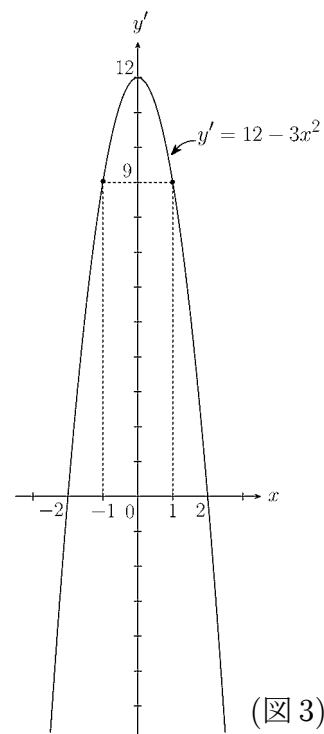

## &lt; 21 ページ. 関数の増減 3 &gt;

## 問の解答

(1)  $y = -x^3 + 3x^2$

$$y' = -3x^2 + 6x$$

$$= -3x(x - 2)$$

$x$	$x < 0$	0	$0 < x < 2$	2	$2 < x$
$y'$	-	0	+	0	-
$y$	↘	0	↗	4	↘

(2)  $y = x^3 - 6x^2 + 9x$

$$y' = 3x^2 - 12x + 9$$

$$= 3(x^2 - 4x + 3)$$

$$= 3(x - 1)(x - 3)$$

$x$	$x < 1$	1	$1 < x < 3$	3	$3 < x$
$y'$	+	0	-	0	+
$y$	↗	4	↘	0	↗

## &lt; 22 ページ. 極大・極小 1 &gt;

## 問の解答

$$\begin{aligned}y' &= 6x^2 + 6x - 12 \\ &= 6(x^2 + x - 2) \\ &= 6(x - 1)(x + 2)\end{aligned}$$

$x$	...	-2	...	1	...
$y'$	+	0	-	0	+
$y$	↗	20	↘	-7	↗

$$\underline{x = -2 \text{ のとき極大値 } y = 20}$$

$$\underline{x = 1 \text{ のとき極小値 } y = -7}$$

## &lt; 23 ページ. 極大・極小 2 &gt;

## 問の解答

(1)  $y' = -4x^3 + 4x$

$$= -4x(x^2 - 1)$$

$$= -4x(x - 1)(x + 1)$$

$x$	...	-1	...	0	...	1	...
$y'$	+	0	-	0	+	0	-
$y$	↗	6	↘	5	↗	6	↘

$$\left( \begin{array}{l} x = \pm 1 \quad \text{のとき極大値} \quad y = 6 \\ x = 0 \quad \text{のとき極小値} \quad y = 5 \end{array} \right.$$

(2)  $y' = 12x^3 - 24x^2 - 36x$

$$= 12x(x^2 - 2x - 3)$$

$$= 12x(x - 3)(x + 1)$$

$x$	...	-1	...	0	...	3	...
$y'$	-	0	+	0	-	0	+
$y$	↘	-7	↗	0	↘	-135	↗

$$\left( \begin{array}{l} x = -1 \quad \text{のとき極小値} \quad y = -7 \\ x = 0 \quad \text{のとき極大値} \quad y = 0 \\ x = 3 \quad \text{のとき極小値} \quad y = -135 \end{array} \right.$$

## &lt; 24 ページ. 関数のグラフ &gt;

## 問の解答

(1)  $y' = 3x^2 - 6x = 3x(x - 2)$

$x$	...	0	...	2	...
$y'$	+	0	-	0	+
$y$	↗	2	↘	-2	↗

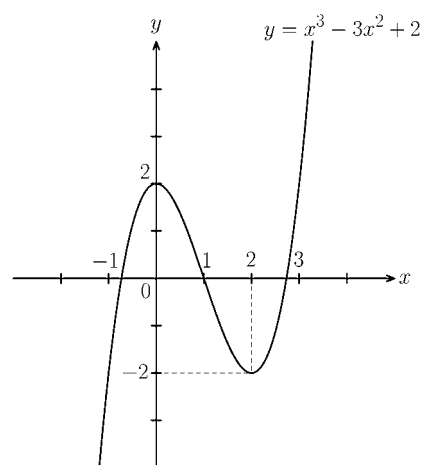
 $x = 0$  のとき極大値  $y = 2$  $x = 2$  のとき極小値  $y = -2$ 

(2)  $y' = 12x^3 - 12x^2 - 24x$

$= 12x(x^2 - x - 2)$

$= 12x(x - 2)(x + 1)$

$x$	...	-1	...	0	...	2	...
$y'$	-	0	+	0	-	0	+
$y$	↘	15	↗	20	↘	-12	↗

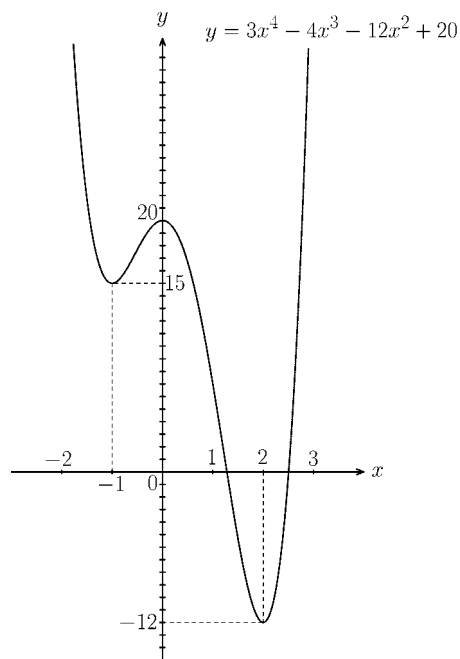
 $x = -1$  のとき極小値  $y = 15$  $x = 0$  のとき極大値  $y = 20$  $x = 2$  のとき極小値  $y = -12$ 

< 25 ページ. 最大・最小 1 >

問の解答

$$\begin{aligned}y' &= 3x^2 - 12x + 9 \\ &= 3(x^2 - 4x + 3) \\ &= 3(x - 3)(x - 1)\end{aligned}$$

$x$	-1	...	1	...	3
$y'$	<del> </del>	+	0	-	<del> </del>
$y$	-19	↗	1	↘	-3

$x = 1$  のとき最大値  $y = 1$

$x = -1$  のとき最小値  $y = -19$

< 26 ページ. 最大・最小 2 >

問の解答

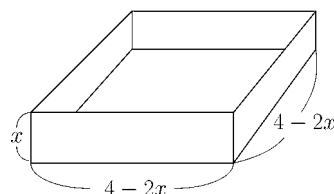
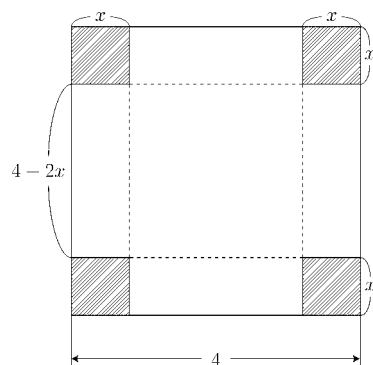

$$\begin{aligned}
 y &= x(4-2x)^2 \\
 &= x(16-16x+4x^2) \\
 &= 4x^3-16x^2+16x \\
 y' &= 12x^2-32x+16 \\
 &= 4(3x^2-8x+4) \\
 &= 4(3x-2)(x-2)
 \end{aligned}$$

$x$  の範囲は  $0 < x < 2$  である

$x$	0	...	$\frac{2}{3}$	...	2
$y'$	$\times$	+	0	-	$\times$
$y$	0	$\nearrow$	$\frac{128}{27}$	$\searrow$	0

$$x = \frac{2}{3} \Rightarrow y = \frac{128}{27}$$

(答)  $x = \frac{2}{3}$ (cm) のとき最大容積  $y = \frac{128}{27}$ (cm)

## &lt; 27 ページ. 微分記号 &gt;

## 問の解答

(1)  $\frac{dy}{dx} = 2x - 1$

(2)  $\frac{dy}{dt} = -9.8$

(3)  $\frac{d\ell}{dt} = 6t - 2$

(4)  $\frac{dS}{dr} = 2\pi r$

(5)  $\frac{dV}{dr} = 4\pi r^2$

## &lt; 28 ページ. 時間の関数 &gt;

## 問 1 の解答

$$(1) f(2) = 19.6 \qquad (2) f(4) = 78.4 \qquad (3) f(3.5) = 60.025$$

## 問 2 の解答

$$\begin{array}{ll} x(0) = 0 & y(0) = 0 \\ x(1) = 19.6 & y(1) = 14.7 \\ x(2) = 39.2 & y(2) = 19.6 \end{array}$$

## 問 3 の解答

$$x'(t) = \lim_{h \rightarrow 0} \frac{x(t+h) - x(t)}{h}, \quad v'(t) = \lim_{h \rightarrow 0} \frac{v(t+h) - v(t)}{h}$$

## 問 4 の解答

$$(1) f'(3) = \lim_{h \rightarrow 0} \frac{4.9 \times (3+h)^2 - 4.9 \times 3^2}{h} \qquad (2) f'(t) = \lim_{h \rightarrow 0} \frac{4.9 \times (t+h)^2 - 4.9 \times t^2}{h}$$

## 問 5 の解答

$$\begin{array}{l} x'(t) = 29.4 \\ y'(t) = -9.8t + 29.4 \\ v'(t) = 0 \end{array}$$

## &lt; 29 ページ. 平均速度 &gt;

## 問 1 の解答

$$72(\text{km/h}) = \frac{72\text{km}}{60\text{min}} = \boxed{1.2} (\text{km/min}) = \boxed{20} (\text{m/s})$$

## 問 2 の解答

$$(1) \frac{4.9 \times 3^2 - 4.9 \times 1^2}{3 - 1} = \frac{44.1 - 4.9}{2} = \frac{39.2}{2} = 19.6(\text{m/s})$$

$$(2) \frac{4.9 \times 4^2 - 4.9 \times 3^2}{4 - 3} = \frac{4.9}{1} (4^2 - 3^2) = 4.9 \times 7 = 34.3(\text{m/s})$$

$$(3) \frac{4.9 \times 3.5^2 - 4.9 \times 3^2}{3.5 - 3} = \frac{4.9}{0.5} (3.5^2 - 3^2) = 9.8 \times 3.25 = 31.85(\text{m/s})$$

$$(4) \frac{4.9 \times 3.1^2 - 4.9 \times 3^2}{3.1 - 3} = \frac{4.9}{0.1} (3.1^2 - 3^2) = 49 \times 0.61 = 29.89(\text{m/s})$$

## &lt; 30 ページ. 瞬間の速度 1 &gt;

## 問 1 の解答

$$\begin{aligned}(1) \quad \frac{4.9 \times 3.01^2 - 4.9 \times 3^2}{3.01 - 3} &= \frac{4.9}{0.01} (3.01^2 - 3^2) \\ &= 490 \times 0.0601 \\ &= 29.449(\text{m/s})\end{aligned}$$

$$\begin{aligned}(2) \quad \frac{4.9 \times (3+h)^2 - 4.9 \times 3^2}{3+h-3} &= \frac{4.9}{h} \times \{9 + 6h + h^2 - 9\} \\ &= \frac{4.9}{h} (6h + h^2) \\ &= 4.9(6 + h) \\ &= 29.4 + 4.9h(\text{m/s})\end{aligned}$$

$$(3) \quad \lim_{h \rightarrow 0} \frac{4.9(t+h)^2 - 4.9t^2}{t+h-t} = 9.8t + 4.9h(\text{m/s})$$

$$(4) \quad \textcircled{1} \quad \lim_{h \rightarrow 0} (29.4 + 4.9h) = 29.4(\text{m/s})$$

$$\textcircled{2} \quad \lim_{h \rightarrow 0} (9.8t + 4.9h) = 9.8t(\text{m/s})$$

$$(5) \quad \textcircled{1} \quad \lim_{h \rightarrow 0} \frac{4.9(3+h)^2 - 4.9 \times 3^2}{(3+h) - 3} = 29.4(\text{m/s})$$

$$\textcircled{2} \quad 9.8t(\text{m/s})$$

$$\textcircled{3} \quad 9.8 \times 4 = 39.2(\text{m/s})$$

## &lt; 31 ページ. 瞬間の速度 2 &gt;

## 問 1 の解答

(1) 2 秒後の速度 =  $f'(2) = 9.8 \times 2 = 19.6(\text{m/s})$

(2) 5 秒後の速度 =  $f'(5) = 9.8 \times 5 = 49.0(\text{m/s})$

## 問 2 の解答

(1)  $v(t) = f'(t) = -9.8t + 29.4(\text{m/s})$

(2)  $v(0) = -9.8 \times 0 + 29.4 = 29.4(\text{m/s})$

(3)  $v(t) = -9.8t + 29.4 = 0 \Leftrightarrow t = 3$  (答) 3 秒後

(4)  $f(3) = 83.3(\text{m})$

## &lt; 32 ページ. 速度の応用 1 &gt;

## 問の解答

$$(1) v(t) = y'(t) = -9.8t + 19.6(\text{m/s})$$

$$(2) v(0) = 19.6(\text{m/s})$$

$$(3) v(t) = -9.8t + 19.6 = 0 \Leftrightarrow t = 2 \quad \underline{\text{(答) 2 秒後}}$$

$$(4) y(2) = 44.1(\text{m})$$

$$(5) y(t) = -4.9t^2 + 19.6t + 24.5 = 0$$

$$\downarrow \div 4.9$$

$$-t^2 + 4t + 5 = 0$$

$$\downarrow$$

$$t^2 - 4t - 5 = (t - 5)(t + 1) = 0 \quad \underline{\text{(答) 5 秒後}}$$

## &lt; 33 ページ. 速度の応用 2 &gt;

## 問の解答

(1)  $v_x(t) = x'(t) = 14.7(\text{m/s})$

(2)  $v_y(t) = y'(t) = -9.8t + 19.6(\text{m/s})$

(3)  $v_y(t) = -9.8t + 19.6 = 0 \Rightarrow t = 2$  (答) 2 秒後

(4)  $y(2) = 19.6$  (答) 19.6(m)

(5)  $y(t) = -4.9t^2 + 19.6t = 0$

$$-4.9t(t - 4) = 0$$
 (答) 4 秒後

(6)  $x(4) = 14.7 \times 4 = 58.8$  (答) 58.8(m)

## &lt; 34 ページ. 速度の応用 3 &gt;

## 問の解答

(1)  $v_x(t) = x'(t) = 29.4(\text{m/s})$

$$v_y(t) = y'(t) = -9.8t + 29.4(\text{m/s})$$

(2)  $v_y(t) = -9.8t + 29.4 = 0 \Rightarrow t = 3$  (答) 3 秒後

(3) 高さ =  $y(3) = 78.4$  (答) 78.4m

水平距離 =  $x(3) = 88.2$  (答) 88.2m

(4)  $y(t) = -4.9t^2 + 29.4t + 34.3 = 0$

$$\downarrow \div(-4.9)$$

$$t^2 - 6t - 7 = 0$$

$$\downarrow$$

$$(t - 7)(t + 1) = 0$$

(答) 7 秒後

(5)  $x(7) = 29.4 \times 7 = 205.8$  (答) 205.8m

## &lt; 35 ページ. 速度と速さ &gt;

**問 1 の解答**

$$\text{速度 } \vec{v}(1.5) = (2, -8 \times 1.5 + 8) = (2, -4)$$

$$\text{速さ } |\vec{v}(1.5)| = \sqrt{2^2 + (-4)^2} = \sqrt{20} = 2\sqrt{5}$$

**問 2 の解答**

$$\vec{v}(t) = (4, -6t + 9)$$

$$\text{速度 } \vec{v}(1) = (4, 3)$$

$$\text{速さ } |\vec{v}(1)| = \sqrt{4^2 + 3^2} = 5$$

< 36 ページ. 微分の応用 >

問 1 の解答

- (1)  $x = -1$  のとき極大値  $y = 5$   
 $x = 3$  のとき極小値  $y = -27$

$x$	...	-1	...	3	...
$y'$	+	0	-	0	+
$y$	↗	5	↘	-27	↗

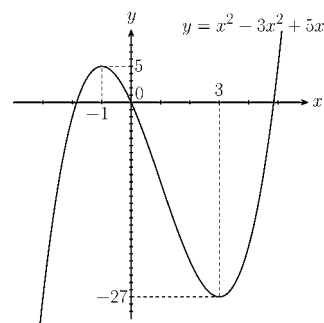

- (2)  $x = 0$  のとき極大値  $y = 0$   
 $x = 1$  のとき極小値  $y = -1$

$x$	...	0	...	1	...
$y'$	+	0	-	0	+
$y$	↗	0	↘	-1	↗

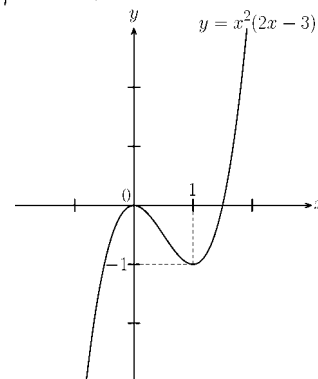

- (3)  $x = \frac{3}{2}$  のとき極大値  $y = \frac{81}{16}$   
 $x = 0, 3$  のとき極小値  $y = 0$

$x$	...	0	...	$\frac{3}{2}$	...	3	...
$y'$	-	0	+	0	-	0	+
$y$	↘	0	↗	$\frac{81}{16}$	↘	0	↗

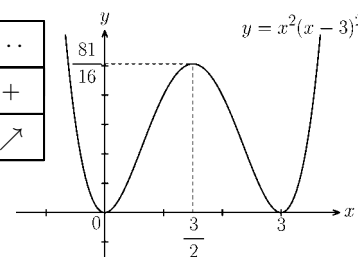

問 2 の解答

- (1)  $x = -2$  のとき最大値  $y = 7$   
 $x = 1$  のとき最小値  $y = -2$

$x$	-2	...	1
$y'$	0	-	-
$y$	7	↘	-2

- (2)  $x = 3$  のとき最大値  $y = 27$   
 $x = -1, 5$  のとき最小値  $y = -5$

$x$	-2	...	-1	...	3	...	5
$y'$	↘	-	0	+	0	-	↘
$y$	2	↘	-5	↗	27	↘	-5

問 3 の解答

(1)  $y = x(6 - 2x)(6 - x) = 2x^3 - 18x^2 + 36x$

(2)  $y' = 6x^2 - 36x + 36 = 6\{(x - 3)^2 - 3\}$

(答)  $x = 3 - \sqrt{3}$  (cm)

$x$	0	...	$3 - \sqrt{3}$	...	3
$y'$	↘	+	0	-	↘
$y$	0	↗	$12\sqrt{3}$	↘	0

問 4 の解答

(1)  $v(t) = -9.8t + 29.4$  (m/s)

(2)  $v(t) = 0 \Rightarrow t = 3$

$y(3) = 122.5$

(答) 3 秒後, 高さ 122.5m

(3)  $y(t) = 0 \Rightarrow -4.9t^2 + 29.4t + 78.4 = 0$

$\downarrow \div (-4.9)$   
 $(t - 8)(t + 2) = 0$

(答) 8 秒後

## &lt; 37 ページ. 原始関数 &gt;

## 問の解答

$$(1) \quad x^4 \text{ の原始関数の一般形} = \frac{1}{5}x^5 + C$$

$$(2) \quad x^5 \text{ の原始関数の一般形} = \frac{1}{6}x^6 + C$$

$$(3) \quad x^6 \text{ の原始関数の一般形} = \frac{1}{7}x^7 + C$$

## &lt; 38 ページ. 不定積分 1 &gt;

## 問 1 の解答

$$(1) \int x^4 dx = \frac{1}{5}x^5 + C$$

$$(2) \int x^5 dx = \frac{1}{6}x^6 + C$$

$$(3) \int x^6 dx = \frac{1}{7}x^7 + C$$

## 問 2 の解答

$$\int x^n dx = \frac{1}{n+1}x^{n+1} + C$$

## &lt; 39 ページ. 不定積分 2 &gt;

## 問 1 の解答

2 式の右辺の関数を微分すると

$$(F(x) + G(x))' = (F(x))' + (G(x))' = f(x) + g(x)$$

より、 $F(x) + G(x)$  は  $f(x) + g(x)$  の原始関数である。

## 問 2 の解答

$$(1) \int 6x^2 dx = 2x^3 + C$$

$$(2) \int (x^2 + x + 1) dx = \frac{1}{3}x^3 + \frac{1}{2}x^2 + x + C$$

$$(3) \int (x^2 + 4x + 3) dx = \frac{1}{3}x^3 + 2x^2 + 3x + C$$

$$(4) \int (2x^2 - x - 1) dx = \frac{2}{3}x^3 - \frac{1}{2}x^2 - x + C$$

## &lt; 40 ページ. 不定積分 3 &gt;

## 問 1 の解答

$$(1) \int (x-2)^3 dx = \int (x^2 - 4x + 4) dx = \frac{1}{3}x^3 - 2x^2 + 4x + C$$

$$(2) \int (3x+1)^2 dx = \int (9x^2 + 6x + 1) dx = 3x^3 + 3x^2 + x + C$$

$$(3) \int (x-1)(x-2) dx = \int (x^2 - 3x + 2) dx = \frac{1}{3}x^3 - \frac{3}{2}x^2 + 2x + C$$

$$(4) \int (x+1)(x-3) dx = \int (x^2 - 2x - 3) dx = \frac{1}{3}x^3 - x^2 - 3x + C$$

$$(5) \int (2-x)(x-3) dx = \int (-x^2 + 5x - 6) dx = -\frac{1}{3}x^3 + \frac{5}{2}x^2 - 6x + C$$

$$(6) \int (x-\alpha)(x-\beta) dx = \int \{x^2 - (\alpha+\beta)x + \alpha\beta\} dx = \frac{1}{3}x^3 - \frac{\alpha+\beta}{2}x^2 + \alpha\beta x + C$$

## 問 2 の解答

$$(1) F(x) = 3x + C$$

$$F(1) = 3 + C = 2 \Rightarrow C = -1$$

$$\underline{\underline{(答) F(x) = 3x - 1}}$$

$$(2) F(x) = \frac{5}{2}x^2 + 4x + C$$

$$F(2) = \frac{5}{2} \times 4 + 4 \times 2 + C$$

$$= 18 + C = 6 \Rightarrow C = -12$$

$$\underline{\underline{(答) F(x) = \frac{5}{2}x^2 + 4x - 12}}$$

$$(3) F(x) = \frac{2}{3}x^3 - \frac{7}{2}x^2 + C$$

$$F(4) = \frac{2}{3} \times 64 - \frac{7}{2} \times 16 + C$$

$$= \frac{128 - 167}{3} + C = -5 \Rightarrow C = \frac{25}{3} \quad \underline{\underline{(答) F(x) = \frac{2}{3}x^3 - \frac{7}{2}x^2 + \frac{25}{3}}}}$$

$$(4) F(x) = x^4 + 2x^3 + 4x^2 + 5x + C$$

$$F(0) = C = 0 \Rightarrow C = 0$$

$$\underline{\underline{(答) F(x) = x^4 + 2x^3 + 4x^2 + 5x}}$$

## &lt; 41 ページ. 不定積分 4 &gt;

## 問の解答

$$(1) \int (10 - 9.8t) dt = 10t - 4.9t^2 + C$$

$$(2) \int 4\pi r^2 dr = \frac{4}{3}\pi r^3 + C$$

$$(3) \int (6t^2 - 4t + 5) dt = 2t^3 - 2t^2 + 5t + C$$

$$(4) \int (u - 1)(u - 2) dt = \int (u^2 - 3u + 2) du = \frac{1}{3}u^3 - \frac{3}{2}u^2 + 2u + C$$

$$(5) \int (t + 3)^2 dt = \int (t^2 + 6t + 9) dt = \frac{1}{3}t^3 + 3t^2 + 9t + C$$

## &lt; 42 ページ. 不定積分の応用 1 &gt;

## 問 1 の解答

(1)  $F(t) = 5t + C \Rightarrow C = 8$

(答)  $F(t) = 5t + 8$

(2)  $F(t) = -2t^2 + 6t + C$

$F(1) = -2 + 6 + C = 4 + C = 7 \Rightarrow C = 3$  (答)  $F(t) = -2t^2 + 6t + 3$

## 問 2 の解答

$v(t) = -10t + C$

$v(0) = C = 20$

(答)  $v(t) = -10t + 20$

## 問 3 の解答

$y'(t) = -10t + 20$

$y(t) = -5t^2 + 20t + C$

$y(0) = C = 25$

(答)  $y(t) = -5t^2 + 20t + 25$

## 問 4 の解答

$y'(t) = v(t) = -10t + 20 = -10(t - 2)$

$t = 2 \Rightarrow y(2) = -5 \times 4 + 20 \times 2 + 25 = 45$

(答)  $t = 2$  のとき最大値  $y(2) = 45$

$t$	...	2	...
$y'$	+	0	-
$y$	↗	45	↘

## &lt; 43 ページ. 不定積分の応用 2 &gt;

## 問 1 の解答

(1)  $v(t) = -9.8t + 19.6(\text{m/s})$

(2)  $y(t) = \int (-9.8t + 19.6)dt$

$= -4.9t^2 + 19.6t + C$

(答)  $y(t) = -4.9t^2 + 19.6t + 58.8(\text{m})$

(3)  $y'(t) = v(t)$

$= -9.8t + 19.6$

$= -9.8(t - 2)$

$t$	...	2	...
$y'$	+	0	-
$y$	↗	78.4	↘

(4) (3) の増減表より、2 秒後に最高点に達する。

そのときの高さ  $y$  は 78.4m、速度  $v$  は 0(m/s)。

(5)  $-4.9t^2 + 19.6t + 58.8 = 0$

$t^2 - 4t - 12 = 0$

$(t - 6)(t + 2) = 0$

$t = 6, -2$

(6) 6 秒後

## 問 2 の解答

(1)  $v(t) = -9.8t + 39.2(\text{m/s})$

(2)  $y(t) = -4.9t^2 + 39.2t + 44.1(\text{m})$

(3) ボールが最高点に達するのは  $v(t) = 0$  を満たすときである。

すなわち、(1) の式

$v(t) = -9.8t + 39.2 = -9.8(t - 4) = 0$

となるときであり、これを満たすのは  $t = 4$  のときである。よって、ボールが最高点に達するのは 4 秒後 である。

また、そのときの高さは

$y(4) = -4.9 \times 16 + 39.2 \times 4 + 44.1 = \underline{122.5\text{m}}$

となる。

(4)  $y(t) = -4.9t^2 + 39.2t + 44.1 = 0$

$t^2 - 8t - 9 = 0$

$(t - 9)(t + 1) = 0$

(答) 9 秒後

## &lt; 44 ページ. 定積分 1 &gt;

## 問の解答

$$(1) \int_a^b 2x dx = [x^2]_a^b = b^2 - a^2$$

$$(2) \int_a^b 4x^3 dx = [x^4]_a^b = b^4 - a^4$$

## &lt; 45 ページ. 定積分 2 &gt;

## 問の解答

$$(1) \int_4^9 1 dx = [x]_4^9 = 5$$

$$(2) \int_{-1}^2 x dx = \left[ \frac{1}{2} x^2 \right]_{-1}^2 = \frac{3}{2}$$

$$(3) \int_{-2}^1 x^2 dx = \left[ \frac{1}{3} x^3 \right]_{-2}^1 = 3$$

$$(4) \int_{-2}^2 x^3 dx = \left[ \frac{1}{4} x^4 \right]_{-2}^2 = 0$$

$$(5) \int_{-1}^1 (x^3 + x^2 + x) dx = \left[ \frac{1}{4} x^4 + \frac{1}{3} x^3 + \frac{1}{2} x^2 \right]_{-1}^1 = \frac{2}{3}$$

$$(6) \int_0^4 (x^3 + 3x^2 - 5x) dx = \left[ \frac{1}{4} x^4 + x^3 - \frac{5}{2} x^2 \right]_0^4 = 88$$

$$\begin{aligned} (7) \int_{-1}^2 (x+1)(x-2) dx &= \int_{-1}^2 (x^2 - x - 2) dx \\ &= \left[ \frac{1}{3} x^3 - \frac{1}{2} x^2 - 2x \right]_{-1}^2 \\ &= -\frac{9}{2} \end{aligned}$$

$$\begin{aligned} (8) \int_a^b (x-a)(x-b) dx &= \int_a^b (x^2 - (a+b)x + ab) dx \\ &= \left[ \frac{1}{3} x^3 - \frac{a+b}{2} x^2 + abx \right]_a^b \\ &= \left( \frac{b^3}{3} - \frac{a+b}{2} b^2 + ab^2 \right) - \left( \frac{a^3}{3} - \frac{a+b}{2} a^2 + a^2 b \right) \\ &= \frac{1}{6} \{ 2b^3 - 3ab^2 - 3b^3 + 6ab^2 - (2a^3 - 3a^3 - 3a^2b + 6a^2b) \} \\ &= \frac{1}{6} \{ -b^3 + 3ab^2 - (-a^3 + 3a^2b) \} \\ &= \frac{1}{6} (a-b)^3 \end{aligned}$$

## &lt; 46 ページ. 定積分 3 &gt;

## 問 1 の解答

$$\begin{aligned}
\int (f(x) + g(x)) dx &= F(x) + G(x) + C \text{ より、} \\
\int_a^b (f(x) + g(x)) dx &= [F(x) + G(x)]_a^b \\
&= F(b) + G(b) - F(a) - G(a) \\
&= \{F(b) - F(a)\} + \{G(b) - G(a)\} \\
&= [F(x)]_a^b + [G(x)]_a^b \\
&= \int_a^b f(x) dx + \int_a^b g(x) dx
\end{aligned}$$

## 問 2 の解答

$$\begin{aligned}
\int_b^a f(x) dx &= [F(x)]_b^a \\
&= F(a) - F(b) \\
&= -(F(b) - F(a)) \\
&= -([F(x)]_a^b) \\
&= -\int_a^b f(x) dx
\end{aligned}$$

## 問 3 の解答

$$\begin{aligned}
(1) \int_1^3 kx^2 dx &= k \int_1^3 x^2 dx = k \left[ \frac{1}{3} x^3 \right]_1^3 = \frac{26}{3} k \\
(2) \int_0^1 (x^2 + 3x) dx + \int_0^1 (x^2 - 3x) dx &= \int_0^1 \{(x^2 + 3x) + (x^2 - 3x)\} dx \\
&= \int_0^1 2x^2 dx = \left[ \frac{2}{3} x^3 \right]_0^1 = \frac{2}{3} \\
(3) \int_{-1}^{-1} (x^2 + x + 4) dx &= 0 \\
(4) \int_{-1}^0 (x^2 + 2x) dx + \int_0^1 (x^2 + 2x) dx + \int_1^3 (x^2 + 2x) dx &= \int_{-1}^3 (x^2 + 2x) dx \\
&= \left[ \frac{1}{3} x^3 + x^2 \right]_{-1}^3 = \frac{52}{3} \\
(5) \int_1^3 (x^2 - x) dx + \int_3^1 (x^2 - x) dx &= \int_1^1 (x^2 - x) dx = 0
\end{aligned}$$

## &lt; 47 ページ. 定積分 4 &gt;

## 問の解答

$$(1) \int_1^3 (4 - 9.8t) dt = [4t - 4.9t^2]_1^3 = -31.2$$

$$(2) \int_0^R 2\pi r dr = [\pi r^2]_0^R = \pi R^2$$

$$(3) \int_0^2 t(t-2) dt = \int_0^2 (t^2 - 2t) dt \\ = \left[ \frac{1}{3}t^3 - t^2 \right]_0^2 = -\frac{4}{3}$$

$$(4) \int_1^4 (t-1)(4-t) dt = \int_1^4 (-t^2 + 5t - 4) dt \\ = \left[ -\frac{1}{3}t^3 + \frac{5}{2}t^2 - 4t \right]_1^4 \\ = \frac{9}{2}$$

$$(5) \int_1^x (t^2 + t) dt = \left[ \frac{t^3}{3} + \frac{t^2}{2} \right]_1^x \\ = \frac{x^3}{3} + \frac{x^2}{2} - \frac{5}{6}$$

$$(6) \int_a^x (6t^2 - 4t) dt = [2t^3 - 2t^2]_a^x \\ = 2x^3 - 2x^2 - 2a^3 + 2a^2$$

## &lt; 48 ページ. 定積分 5 &gt;

## 問 1 の解答

$$(1) \int_1^x (2t+3)dt = [t^2+3t]_1^x = x^2+3x-4$$

$$\frac{d}{dx} \int_1^x (2t+3)dt = \frac{d}{dx}(x^2+3x-4) = 2x+3$$

$$(2) \int_0^x (6t^2+4t+5)dt = [2t^3+2t^2+5t]_0^x = 2x^3+2x^2+5x$$

$$\frac{d}{dx} \int_0^x (6t^2+4t+5)dt = \frac{d}{dx}(2x^3+2x^2+5x) = 6x^2+4x+5$$

$$(3) \int_a^x (5t^2-6t)dt = \left[ \frac{5}{3}t^3-3t^2 \right]_a^x = \frac{5}{3}x^3-3x^2-\frac{5}{3}a^3+3a^2$$

$$\frac{d}{dx} \int_a^x (5t^2-6t)dt = \frac{d}{dx} \left( \frac{5}{3}x^3-3x^2-\frac{5}{3}a^3+3a^2 \right) = 5x^2-6x$$

## 問 2 の解答

$$\int_a^t (6x^2+8x)dx = [2x^3+4x^2]_a^t = 2t^3+4t^2-2a^3-4a^2$$

$$\frac{d}{dt} \int_a^t (6x^2+8x)dx = \frac{d}{dt}(2t^3+4t^2-2a^3-4a^2) = 6t^2+8t$$

## &lt; 49 ページ. 変位と道のり &gt;

## 問の解答

$$\begin{aligned}(1) \int_1^3 (2-t)dt &= \left[2t - \frac{t^2}{2}\right]_1^3 \\ &= \left(6 - \frac{9}{2}\right) - \left(2 - \frac{1}{2}\right) \\ &= 0\end{aligned}$$

$$\begin{aligned}(2) \int_1^3 |2-t|dt &= \int_1^2 |2-t|dt + \int_2^3 |2-t|dt \\ &= \int_1^2 (2-t)dt + \int_2^3 (t-2)dt \\ &= \left[2t - \frac{t^2}{2}\right]_1^2 + \left[\frac{t^2}{2} - 2t\right]_2^3 \\ &= \left(4 - \frac{4}{2}\right) - \left(2 - \frac{1}{2}\right) + \left(\frac{9}{2} - 6\right) - \left(\frac{4}{2} - 4\right) \\ &= 1\end{aligned}$$

## &lt; 50 ページ. 積分の練習 &gt;

## 問 1 の解答

(1)  $\int (3x - 5)dx = \frac{3}{2}x^2 - 5x + C$

(2)  $\int \left( \frac{1}{4}x^2 - 5x + 7 \right) dx = \frac{1}{12}x^3 - \frac{5}{2}x^2 + 7x + C$

(3)  $\int \left( -\frac{1}{3}x^2 + 4x \right) dx = -\frac{1}{9}x^3 + 2x^2 + C$

(4)  $\int (x - 1)(2x + 1)dx = \frac{2}{3}x^3 - \frac{1}{2}x^2 - x + C$

(5)  $\int (t^2 - 4x + 3)dt = \frac{t^3}{3} - 2t^2 + 3t + C$

(6)  $\int (2t + 1)^2 dt = \int (4t^2 + 4t + 1)dt = \frac{4}{3}t^3 + 2t^2 + t + C$

## 問 2 の解答

(1)  $\int_{-1}^1 (x^2 - 4x + 3)dx = \left[ \frac{1}{3}x^3 - 2x^2 + 3x \right]_{-1}^1 = \frac{20}{3}$

(2)  $\int_{-1}^3 (x + 1)(x - 3)dx = \int_{-1}^3 (x^2 - 2x - 3)dx = \left[ \frac{1}{3}x^3 - x^2 - 3x \right]_{-1}^3 = -\frac{32}{3}$

(3)  $\int_0^2 (t - 1)^2 dt = \int_0^2 (t^2 - 2t + 1)dt = \left[ \frac{1}{3}t^3 - t^2 + t \right]_0^2 = \frac{2}{3}$

(4)  $\int_1^3 |10 - 5t|dt = \int_1^2 (10 - 5t) + \int_2^3 (5t - 10)dt = 5$

## 問 3 の解答

(1)  $F(t) = -\frac{5}{2}t^2 + 10t + C$

$F(1) = -\frac{5}{2} + 10 + C = 3 \Rightarrow C = -\frac{9}{2}$

(答)  $F(t) = -\frac{5}{2}t^2 + 10t - \frac{9}{2}$

(2)  $F(t) = \frac{1}{3}t^3 - 2t^2 + 7t + C$

$F(0) = C = 0$

(答)  $F(t) = \frac{1}{3}t^3 - 2t^2 + 7t$

## 問 4 の解答

(1)  $v(t) = -9.8t + C, \quad v(0) = 19.6 \Rightarrow C = 19.6$

(答)  $v(t) = -9.8t + 19.6(\text{m/s})$

(2)  $y(t) = \int (-9.8t + 19.6)dt = -4.9t^2 + 19.6t + C, \quad y(0) = 0 \Rightarrow C = 0$

(答)  $y(t) = -4.9t^2 + 19.6t(\text{m})$

(3)  $y'(t) = v(t) = 0 \Rightarrow -9.8t + 19.6 = 0 \Rightarrow t = 2, \quad y(2) = 19.6$

(答) 2 秒後に最高の高さ 19.6m に達する

(4) 道のり =  $\int_1^3 |v(t)|dt = \int_1^2 |-9.8t + 19.6|dt = \int_1^2 (-9.8t + 19.6)dt + \int_2^3 (9.8t - 19.6)dt = 9.8$

(答) 9.8m

(4) の別解

◎ 2 秒後に最高点に達する

1 秒後の高さ =  $y(1) = 14.7(\text{m})$

2 秒後の高さ =  $y(2) = 19.6(\text{m})$

3 秒後の高さ =  $y(3) = 14.7(\text{m})$

よって

① 1 秒後から 2 秒後までの間に動いた距離 =  $y(2) - y(1) = 4.9(\text{m})$

② 2 秒後から 3 秒後までの間に動いた距離 =  $y(2) - y(3) = 4.9(\text{m})$

①と②より

(答) 1 秒後から 3 秒後までの間に動いた距離 =  $4.9 + 4.9 = 9.8(\text{m})$

